



# **Residential Water Heater Training**

January 2016

# Introduction

The purpose of this manual is to provide training for employees in the basic concepts of residential electric and gas storage type water heaters.

This manual is organized into the following sections:

**Electric Water Heater Parts**

Photographs, illustrations and a brief description of the parts of an electric water heater.

**Electric Water Heater Operation**

How standard electric water heaters transfer heat into water.

**Gas Water Heater Parts**

Photographs, illustrations and a brief description of the parts of a gas water heater.

**Gas Water Heater Operation**

How standard gas and FVIR water heaters transfer heat into water.

**Applications**

Types of water heaters available and their application.

**Water**

Common potable water sources and how water impurities affect a water heater.

**Specifications**

Formulas and information for determining the efficiency of a water heater.

**Safety**

Corrosion, thermal expansion and excessive water temperatures.

**Maintenance**

Basic water heater maintenance procedures.

**Sizing and Performance**

Definition of hot water, how to determine hot water demand, water heater capacity and efficiency.

**Testing and Standards**

Quality, safety and efficiency standards for water heaters.

**Definitions**

Common terms used throughout this manual.

Upon completion of this manual, the reader should have a basic understanding of electric and gas water heater operations, applications, performance, service issues, safety issues and industry standards.

This manual does not assume any particular skill level or experience of the reader. AOS does not accept any liability for incomplete, outdated or incorrect information provided in this manual. Improper servicing of water heaters can result in property damage, bodily injury or death. Do not attempt to service any water heater if you have any doubt about your ability to do so. Consult a qualified professional.

## Section Index

Introduction .....	2
Standard Electric Water Heater Illustration.....	4
Electric Water Heater Parts .....	5
Energy Smart/Energy Saver Water Heater Illustration	7
Energy Smart/Energy Saver Heater Parts .....	8
Electric Water Heater Operation .....	9
Standard Gas Water Heater Illustration .....	12
FVIR Water Heater Illustration.....	13
FVIR Water Heater Series 100 Illustration .....	14
Gas Water Heater Parts .....	15
Gas Water Heater Operation .....	18
Gas and Electric Water Heater Parts .....	24
Applications .....	26
Water .....	30
Safety .....	32
Sizing and Performance .....	36
Specifications .....	39
Testing and Standards.....	40
Definitions.....	42
Topic Index.....	45

## Photo Index:

Standard Electric Water Heater .....	4
Electric Water Heater Jacket.....	5
Electric Water Heater Insulation.....	5
Electric Water Heater Tank.....	5
Electric Water Heater Element .....	5
Electric Water Heater Control Circuit .....	6
Energy Smart/Energy Saver Electric Water Heater .....	7
Standard Gas Water Heater .....	12
FVIR Water Heater .....	13
FVIR Water Heater Series 100 .....	14
Gas Water Heater Jacket .....	15
Gas Water Heater Insulation .....	15
Gas Water Heater Tank and Flue .....	15
Gas Water Heater Burner .....	16
Gas Water Heater Venting.....	16
Gas & Electric Water Heater Dip Tube.....	25
Gas & Electric Water Anode Rod .....	25
Gas & Electric Water Heater T&P Valve.....	25
Gas & Electric Water Heater Drain Valve.....	25
Heat Traps.....	24
Flames on Flame Trap.....	20,22
FVIR Thermal Cutoff Switch .....	21,23
FVIR Lint Shedding .....	22
Lowboy Water Heater.....	26
Table Top Water Heater .....	26
Tiny Titan® Water Heater .....	27
Mobile Home Water Heater .....	27

Direct Vent Water Heater .....	28
Power Vent Water Heater .....	29
Power Direct Vent Water Heater .....	29
Suspended Solids in Water.....	30
Milky Water .....	30
Scale on Elements.....	31
Depleted Anode Rod .....	32
Electric Reset Button .....	34
FVIR Lint Filter .....	36

## Illustration Index:

How an Electric Water Heater Works .....	9
Standard Gas Valve Front View.....	21
Standard Gas Valve Side View .....	21
How a Gas Water Heater Works .....	21
FVIR Gas Valve .....	21,23
Honeywell Gas Valve Front View.....	23
Honeywell Gas Valve Side View .....	23
Heat Traps .....	24
Atmospheric Venting.....	27
Venting Types .....	28
Direct Venting.....	28
Power Venting .....	29
Power Direct Venting .....	29
Lime Deposit Chart .....	31
Galvanic Corrosion .....	32
Collapsed Flue.....	33
Expansion Tanks .....	33
Common Water Temperatures by Application .....	35
Scald Warning Label .....	35
T&P Valve Operation .....	36
Residential Water Heater Sizing Guide .....	38
Standby Heat Loss .....	39
Energy Guide Label .....	41

## Formula Index:

Gas Recovery Capacity .....	38
Electric Recovery Capacity .....	38
Percentage of Hot Water Required.....	38
Water Use Per Activity .....	38

# Standard Electric Water Heater

This section provides an overview of electric water heaters. The first part of this section has illustrations, photographs and a brief description of each part. The second part of this section describes the operation of standard electric water heaters. When this section is completed, the reader should have a basic understanding of how an electric water heater transfers heat into water.

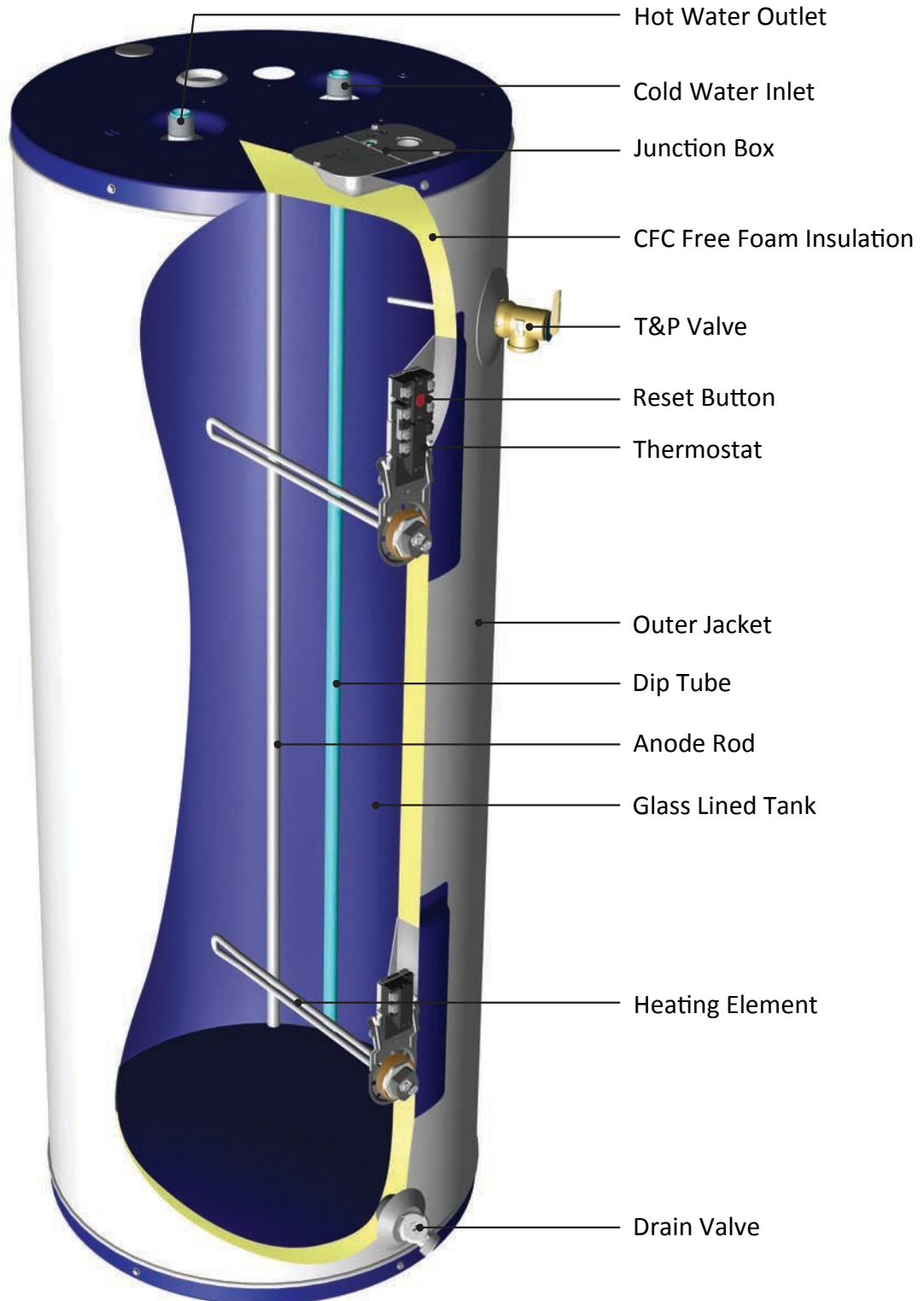

# Electric Water Heater Parts



**Outer Jacket** - The outer jacket of an electric water heater consists of three pieces: the jacket top, jacket skirt and jacket bottom. The jacket provides a space for insulation around the tank, preventing the consumer from coming into contact with hot surfaces and to reduce energy loss. Connections extend from the tank through the outer jacket to provide plumbing connections for the cold water inlet and the hot water outlet.



**Glass Lined Tank** – A water heater tank is constructed of three pieces of steel: a top head, a bottom head and a shell. These three pieces are welded together to form a tank that will withstand a working pressure of 150 pounds per square inch. The interior of the tank is coated with glass lining, baked on at about 1600°F, which will not break or crack, unless it receives a blow severe enough to dent the steel tank. This coating helps protect the tank from the corrosive effects of hot water.

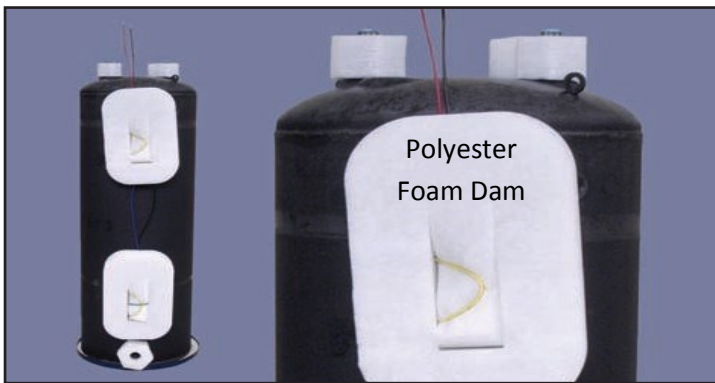

**Insulation** - Between the tank and the outer jacket is a layer of insulation. Three materials are used as insulation in water heaters: CFC free polyurethane foam, fiberglass and polyester. Polyurethane foam is the more efficient of these materials and is injected through a port in the outer jacket in liquid form. This liquid expands quickly filling in the space between the tank and jacket and then dries. Polyester or fiber-glass is used around all openings and controls to ensure that the polyurethane foam does not cover these devices.

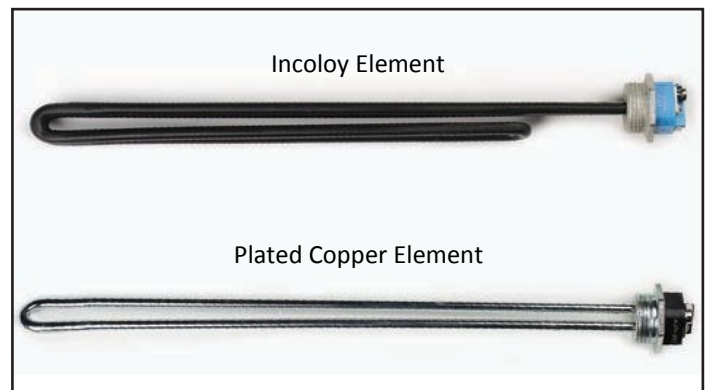

**Element** - The element consists of an inner wire surrounded by filler material enclosed in a sheath of copper or stainless steel. The thermostat allows electrical current to flow through the inner wire and from the wire's resistance it also creates heat which is transferred through the filler material to the outer sheath and is then absorbed by the water. Elements may be available in different wattages and materials to meet specific heating requirements

# Standard Electric Water Heater Parts

**Control Circuit** - The standard single-phase control circuit consists of a high limit control switch with a reset button, upper thermostat, lower thermostat, two heating elements and wires. The upper thermostat first sends electrical energy to the upper element until the water temperature in the upper third of the tank reaches the thermostat setting. Power is then transferred to the lower element until the remaining water reaches the lower thermostat setting. If the water temperature exceeds 170°F the high limit control switch will trip shutting off power to the elements. Single element water heaters have one element mounted at the bottom of the tank controlled by a single thermostat and high limit switch.

## TOD Wiring Diagram

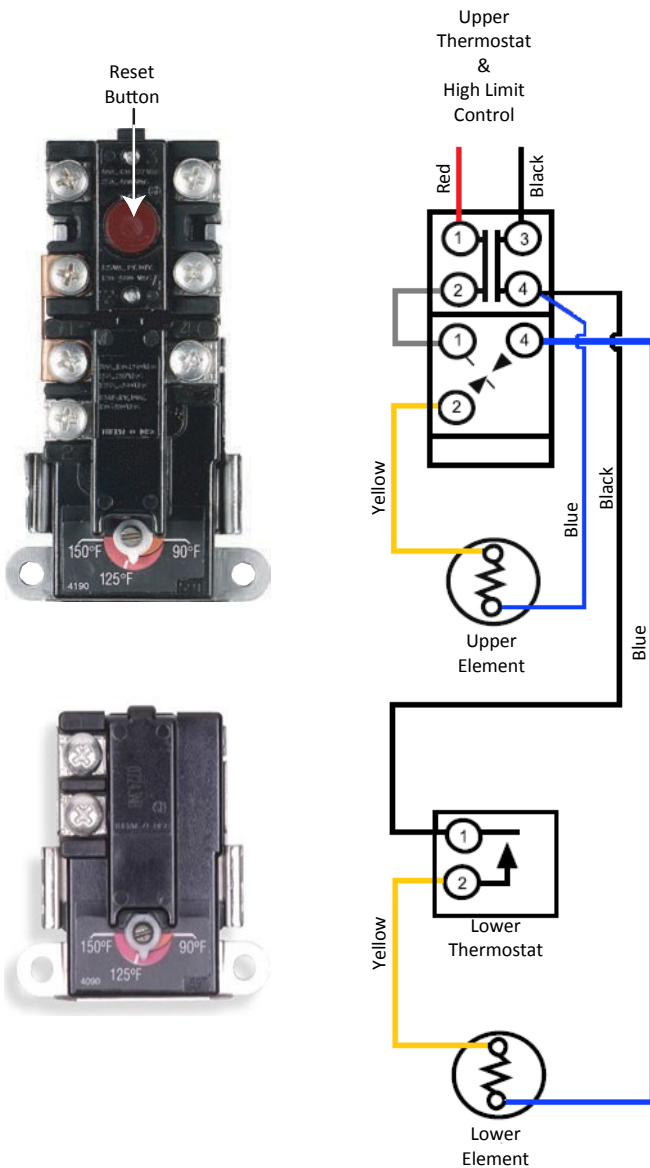

## APCOM Wiring Diagram

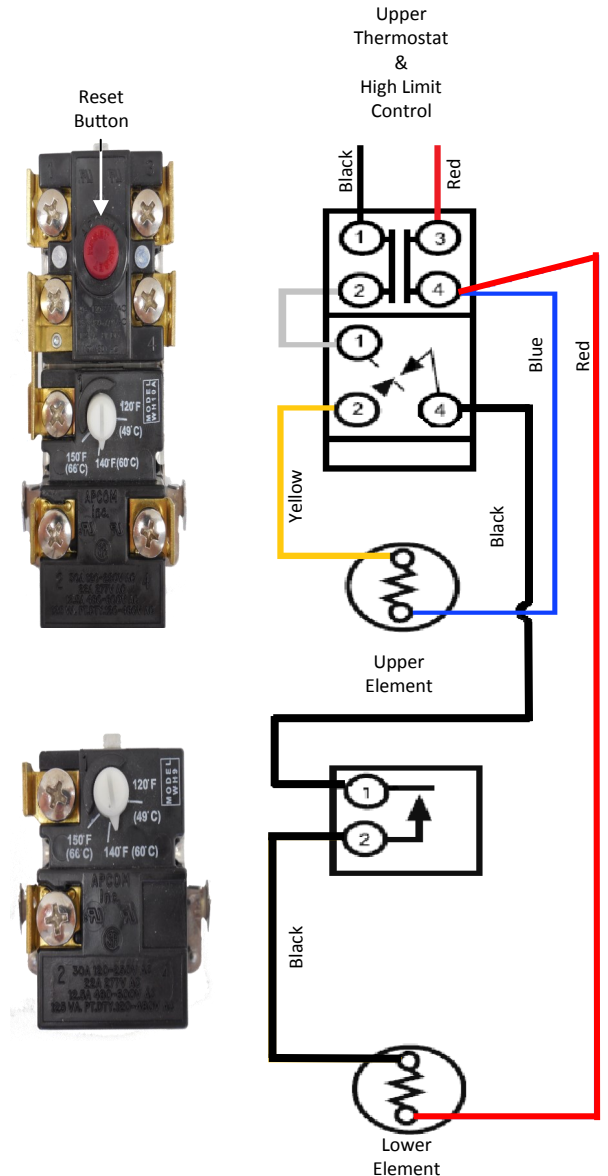

Wire colors will vary depending on manufacturing location

# Energy Smart/Energy Saver Electric Water Heater

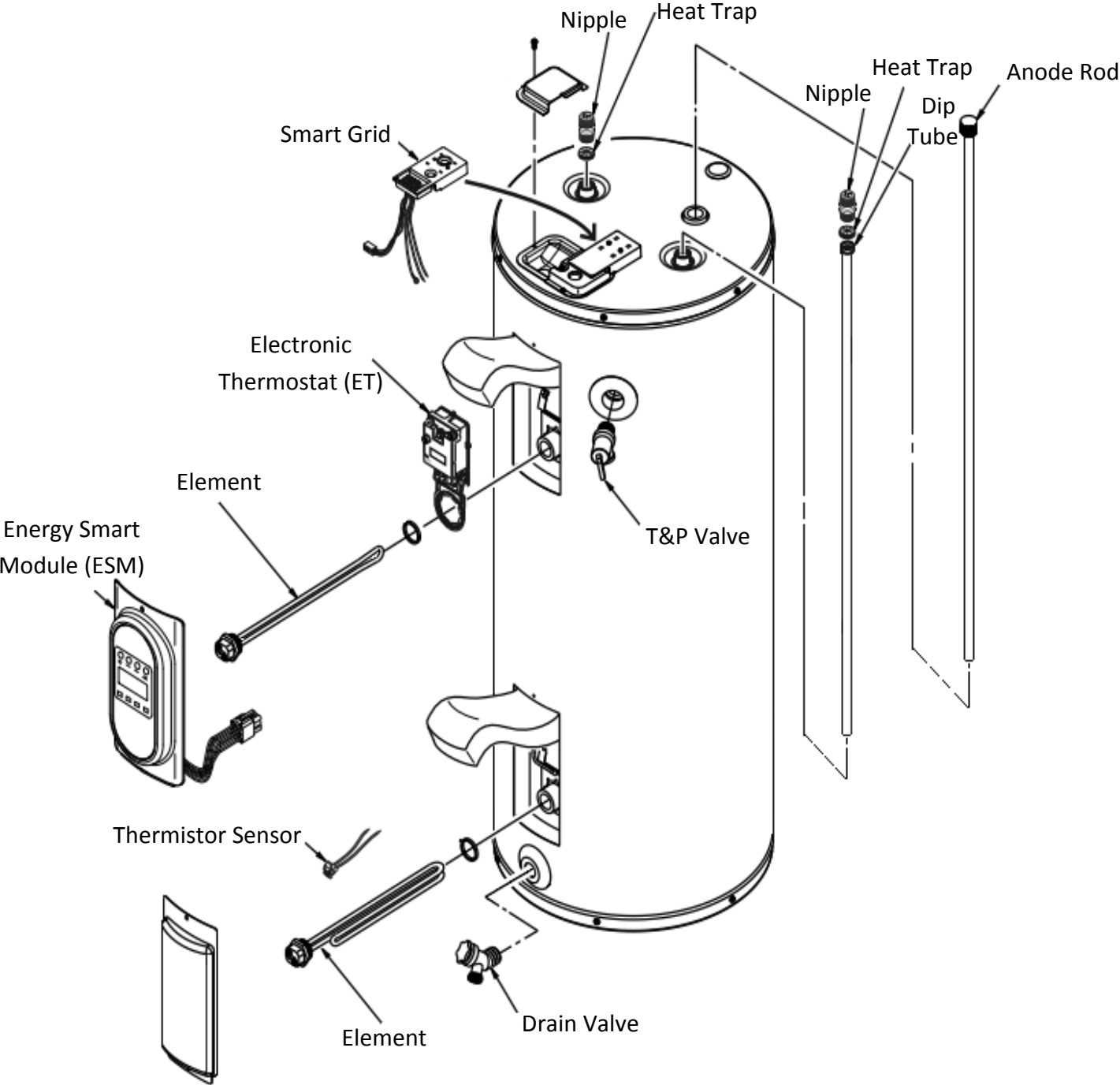



# Energy Smart/Saver Water Heater Parts

**Energy Smart II/Energy Saver Electric Operation** - The ES electric water heater includes an Energy Smart Module (ESM) user interface which allows homeowners to easily adjust the temperature, operating mode, and view diagnostic information without requiring any tools or removal of water heater components. The ESM is connected to an Electronic Thermostat (ET) above the upper element. Additionally, the Smartgrid connector located at the top of the water heater on the electrical junction box is connected and ready for future utility demand response.

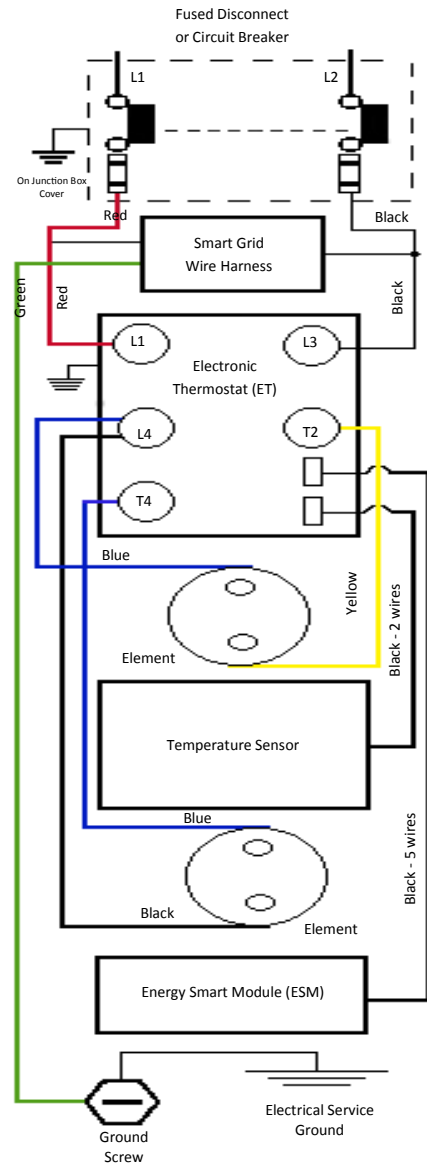
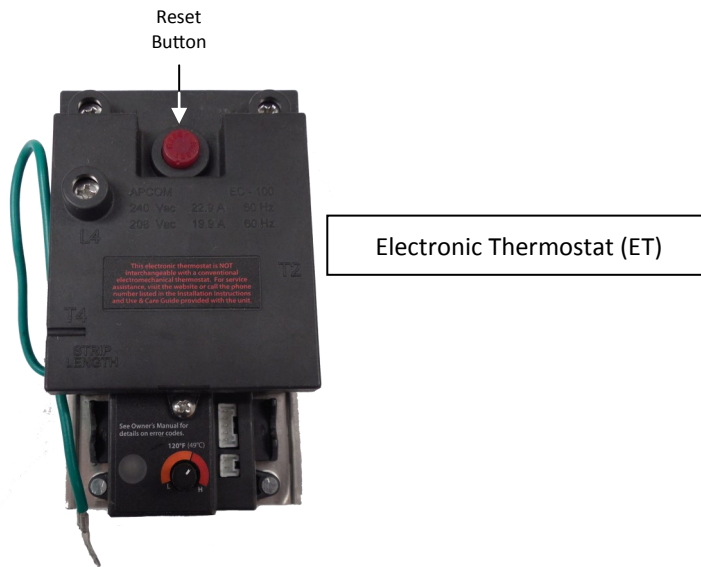
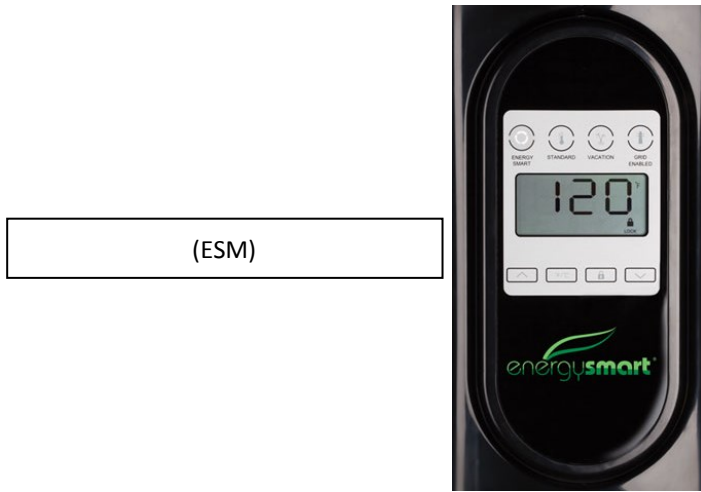



# Electric Water Heater Operation



## Standard Electric

The standard residential electric water heater control circuit consists of a manual reset high limit switch, an upper thermostat, lower thermostat, two heating elements and wires.

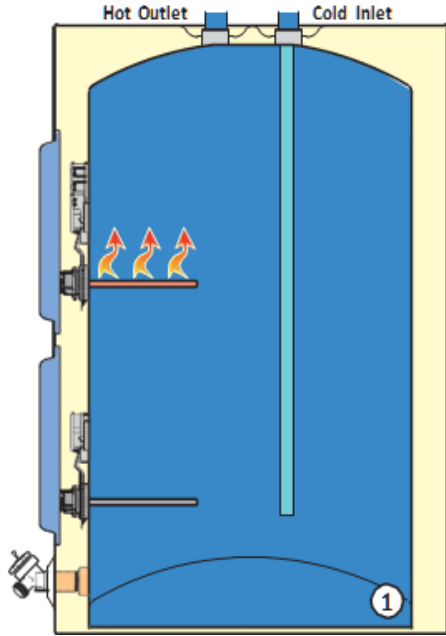

When power is initially turned on to the unit, the upper element is energized and heats the water in the upper third of the tank.

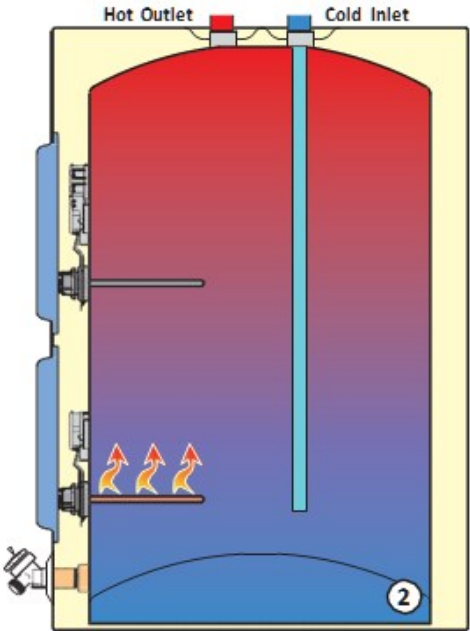

When the upper third of the tank is heated to the temperature set on the upper thermostat, power is switched to the lower heating element. The lower element heats the water in the lower 2/3 of the tank until the lower thermostat is satisfied.

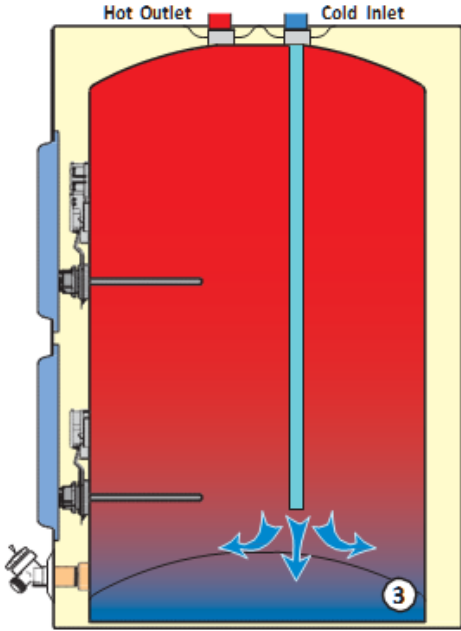

As hot water is drawn from the top of the tank, the dip tube delivers cold water to the bottom of the tank.

# Electric Water Heater Operation

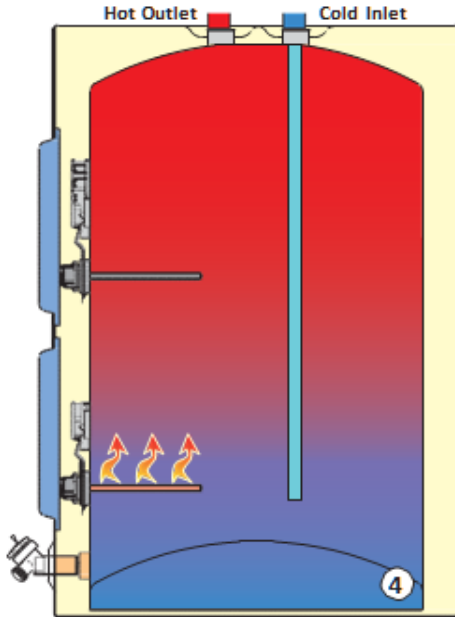

When installing a new electric water heater or following draining the tank for maintenance purposes, the tank should be completely re-filled and purged of air before applying power to the elements. Energizing a heating element that is not fully submerged in water is referred to as "dry firing," and will cause the element to immediately burn out

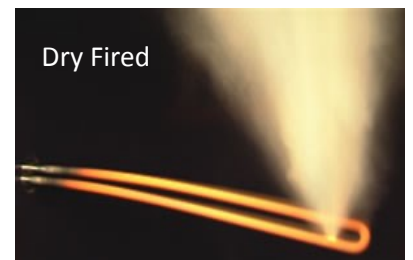

Eventually the cold water mixes with the hot lowering the temperature to below the lower thermostat setting and the bottom element is energized. If enough water is drawn to cool the upper third of the tank, the upper thermostat will send power to the upper element. When the upper third of the tank is heated, power will again be switched to the lower element.

If the upper element is dry fired, the water heater will cease to function because the upper thermostat will never be satisfied and power will never be switched to the lower element.

If water temperature in the tank reaches 170°F, the manual reset high limit switch will be tripped. This switch can be reset by firmly pushing the red button above the upper thermostat. (See photo and wiring diagram on page 7.)

Single element water heaters have one element mounted at the bottom of the tank controlled by a single thermostat and high limit switch.



# Standard Gas Water Heater

This section provides an overview of gas water heaters. The first part of this section has illustrations, photographs and a brief description of each part. The second part of this section describes the operation of standard gas water heaters and F V I R gas water heaters. When this section is completed, the reader should have a basic understanding of how a gas water heater transfers heat into water.

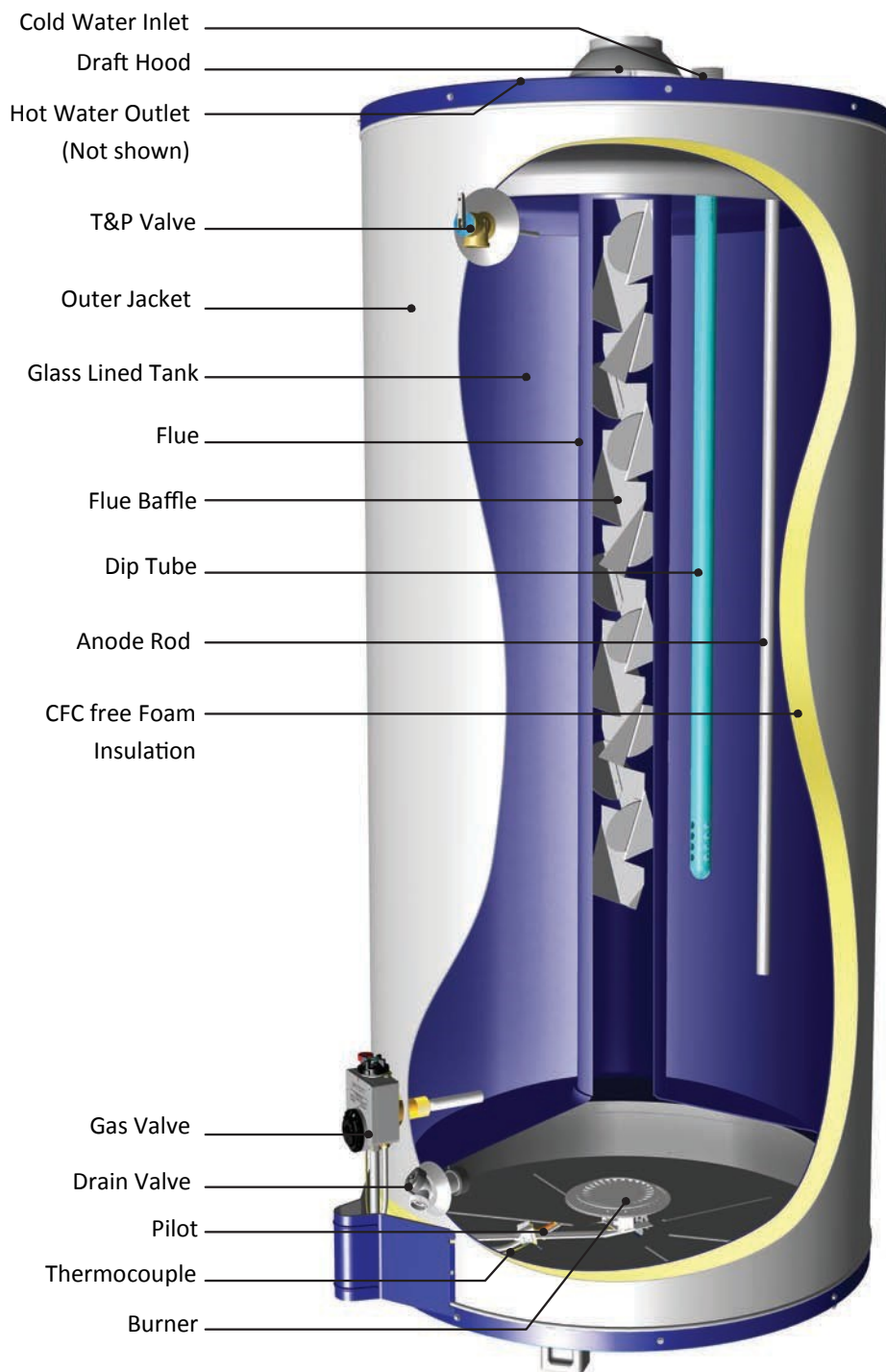

# FVIR Water Heater

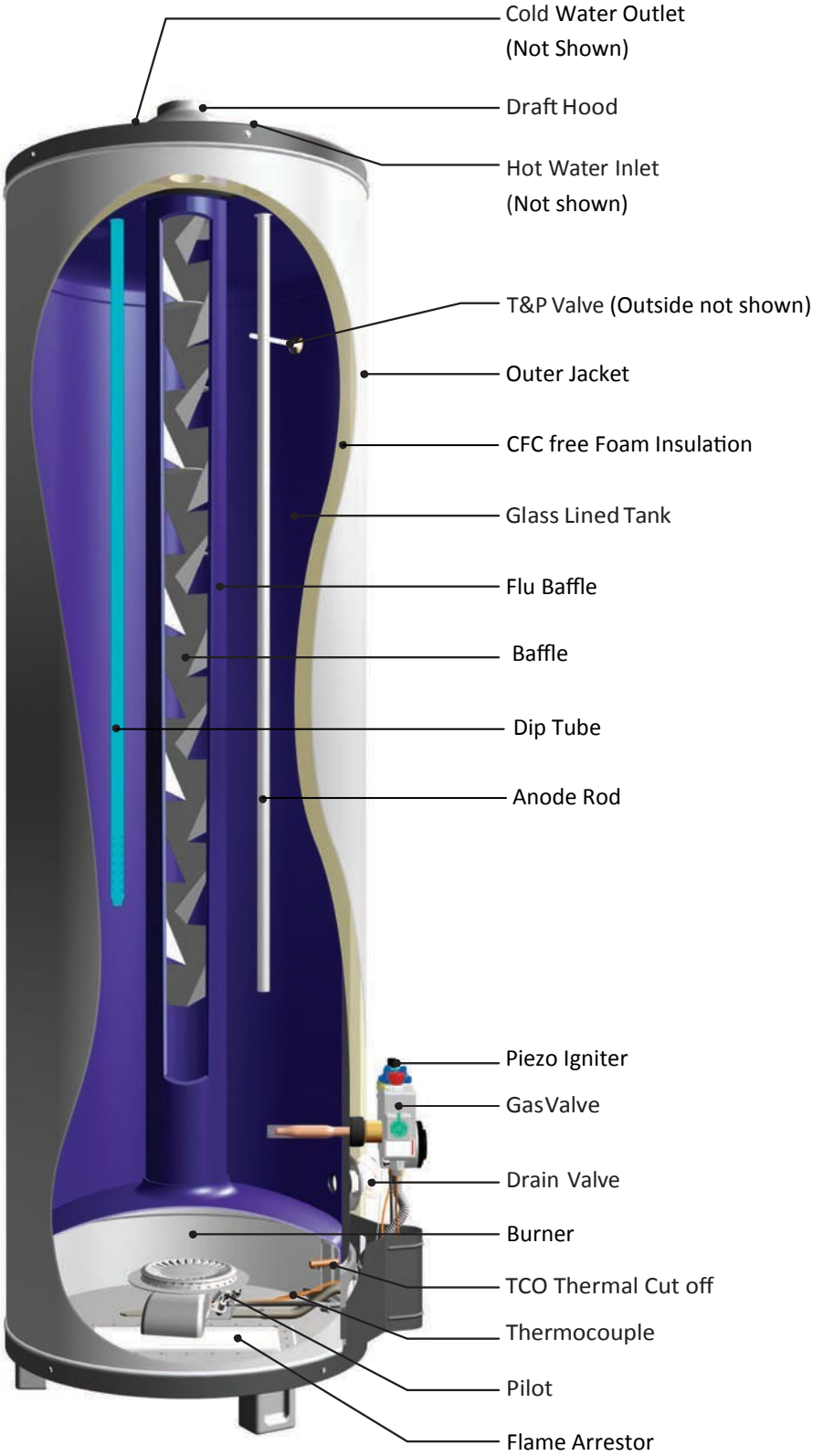



# Gas Water Heater Parts

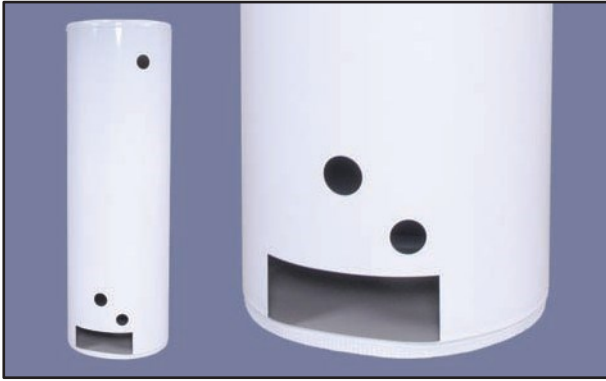

**Outer Jacket** - The outer jacket of a gas water heater consists of three pieces: the jacket top, jacket skirt and jacket base assembly. The jacket provides a space for insulation around the tank. The jacket base assembly is where combustion takes place, and it is designed to shield the floor from excessive temperatures.



**Tank and Flue** - In addition to the top head, bottom head and shell, the gas water heater also has a flue running through the center. As combustion occurs below the bottom head, heat rises into the flue. The flue contains a baffle which is designed to increase the transfer of heat along the flue pipe both the tank and the flue are glass coated to prevent corrosion. On FVIR water heaters, the flue is coated on both the inside and outside.



**Insulation** - Gas water heaters are foam insulated to prevent heat loss. A fiberglass blanket is used around the combustion chamber due to the high temperatures radiated through the combustion chamber walls during burner operation. Foam insulation could not withstand these high temperatures. CFC free polyurethane foam is injected through a port in the outer jacket in liquid form to insulate the remainder of the water heater. This liquid expands quickly, filling the space between the tank and jacket when cured, to reduce standby heat loss.



# Gas Water Heater Parts



Honeywell Gas Valve



**Venting** - The combustion process creates by-product such as carbon dioxide, carbon monoxide and water vapor. These gasses are harmful to breathe and need to be vented outside of the home. On standard atmospheric gas models, a draft hood is positioned at the top of the flue. The draft hood prevents the flame from lifting off the burner. If the vent system is not working, Flue gasses can spill out of the draft hood openings. Some models use direct, power or power direct venting to exhaust flue gasses (See Page 27—29). Ensure the same BTU heater is installed to ensure proper venting

**Gas Valve**— the gas valve has 2 functions. The first function is to regulate the gas pressure down to a usable level for a controlled and safe burn. The second function is to regulate the water temperature based on the set point.



Standard Gas Burner

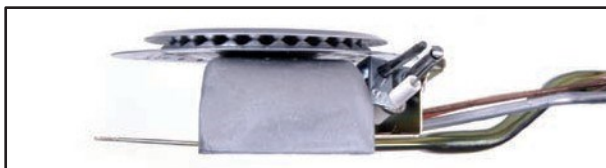

Flame Guard® Burner

**Burner** - The burner is centered under the bottom head and flue. Gas is ignited at the burner by the pilot light. The resulting combustion transfers heat to the water through the bottom head and the flue. Gas water heaters burn either natural gas or L.P.



# Gas Water Heater Operation



The heat from the pilot flame creates an electrical current in the thermocouple circuit that operates a small spring-loaded electromagnet in the gas valve. The Electromagnet holds the main gas supply line interrupter open allowing gas to flow to the pilot and main burner. If the pilot goes out, the electromagnet will no longer receive a current and the spring loaded interrupter will shut off the gas supply.

If the pilot is lit, the gas valve's thermostat controls gas flow to the main burner. The thermostat's sensor is mounted to the back side of the gas valve and is inserted inside the water heater when the gas valve is installed. A knob on the front of the gas valve allows the user to adjust the temperature.

## Standard Gas Water Heaters

In order for a standard gas water heater to operate, the pilot must be lit.

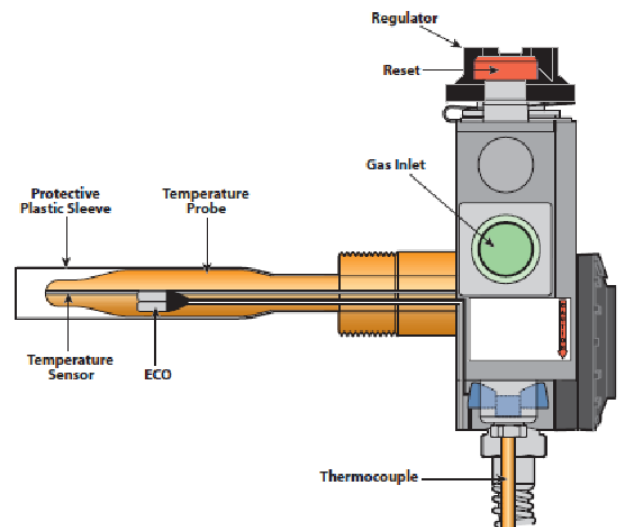
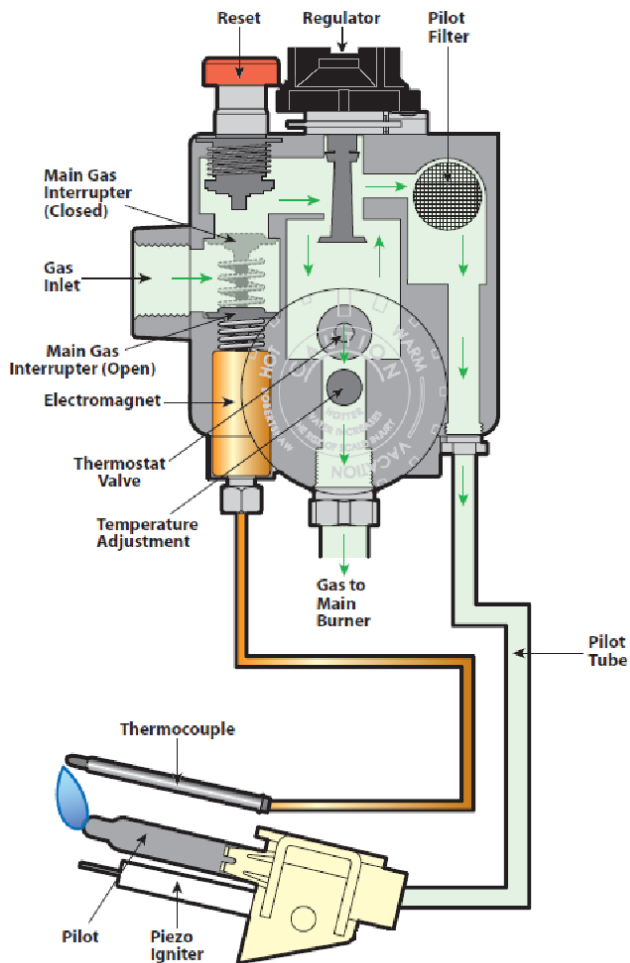

An energy cut off (ECO) switch is mounted inside the probe attached to the back of the gas valve and extends inside the water heater. The ECO functions as a high limit switch. If water temperature inside the tank reaches about 180°F, the ECO disables the water heater. The entire gas valve must be replaced if this happens

# Gas Water Heater Operation

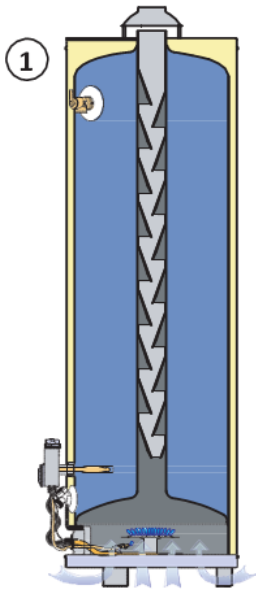

1  
Air for combustion passes through the bottom of the water heater into the combustion chamber. Gas flows into the burner and is ignited by the pilot flame.

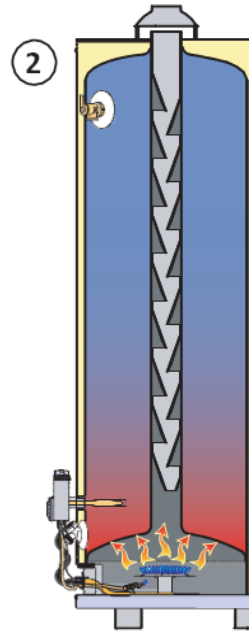

2  
Heat from combustion rises and contacts the tank bottom head being transferred through the steel into the water.

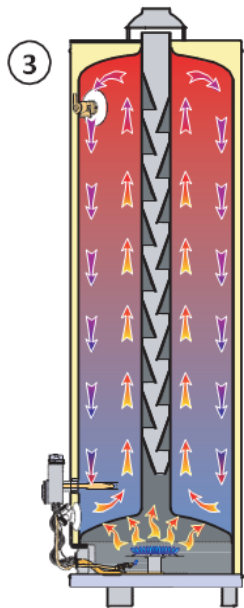

3  
As the heated water rises, cooler water sinks to the bottom of the tank.

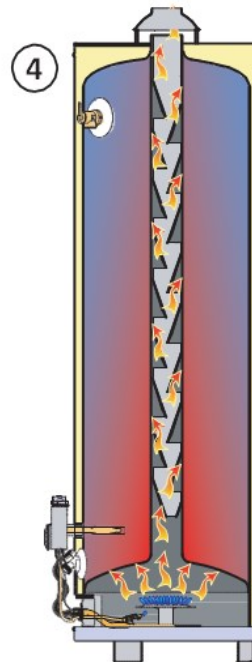

4  
The flue pipe carries away combustion by product gasses as well as acting as a heat transfer surface. At the center of the flue is a baffle. The baffle helps transfer heat by deflecting hot combustion gasses against the sides of the flue where the heat is transferred into the water.

# Gas Water Heater Operation



## FVIR Water Heaters

Spills of gasoline or the presence of other flammable vapors near a standard gas water heater can be very dangerous. The American National Standards Institute (ANSI) now requires all residential water heaters to be flammable vapor ignition resistant (FVIR). All FVIR **Water Heaters** are fully compliant with ANSI FVIR standards.

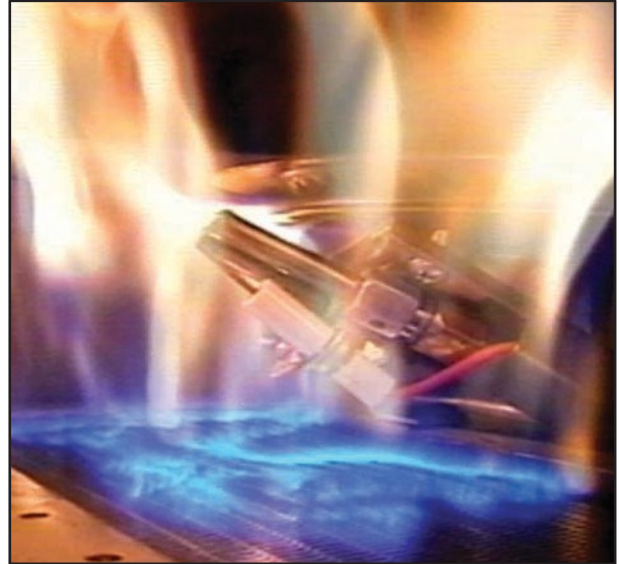

FVIR water heaters have a sealed combustion chamber. Combustion air and flammable vapors can only enter through a specially designed flame arrestor. The flame arrestor is located in the bottom of the combustion chamber, under the main burner and pilot flame. If flammable vapors are present, the pilot or main burner could ignite them inside the combustion chamber. The vapors burn on top of the flame trap and have a reduced likelihood of escaping back into the room. When the vapors become too rich or too lean to burn, they snuff themselves out.

A second part of the ANSI Standard concerns resistance to lint, dust, and other debris build-up on the flame arrestor. If the flame arrestor was to become clogged, combustion air would be reduced, starving the burner of oxygen. This may increase the amount of carbon monoxide and create a health hazard. FVIR water heaters are designed to reduce lint build-up. The small pressure wave created by lighting the burner during normal operation helps blow accumulated lint off the flame trap. If lint does build up, the thermal cutoff switch will shut down the heater, so the flame trap and the filter may be cleaned.

# Gas Water Heater Operation

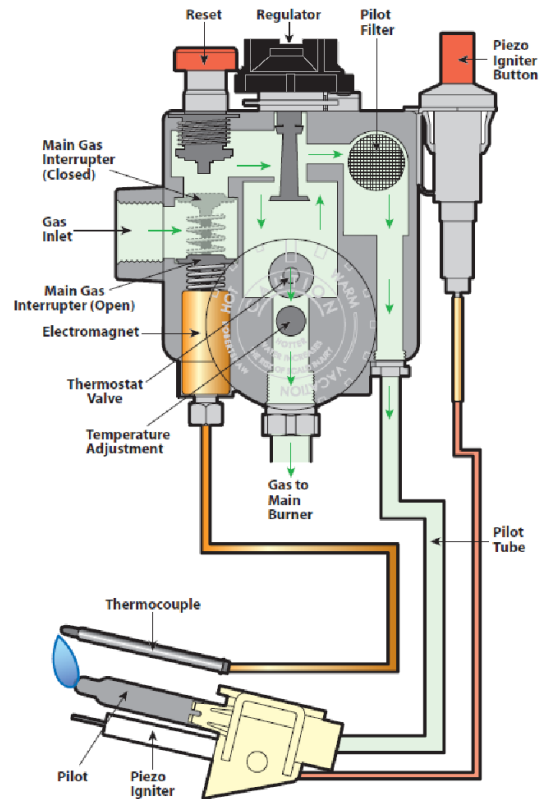
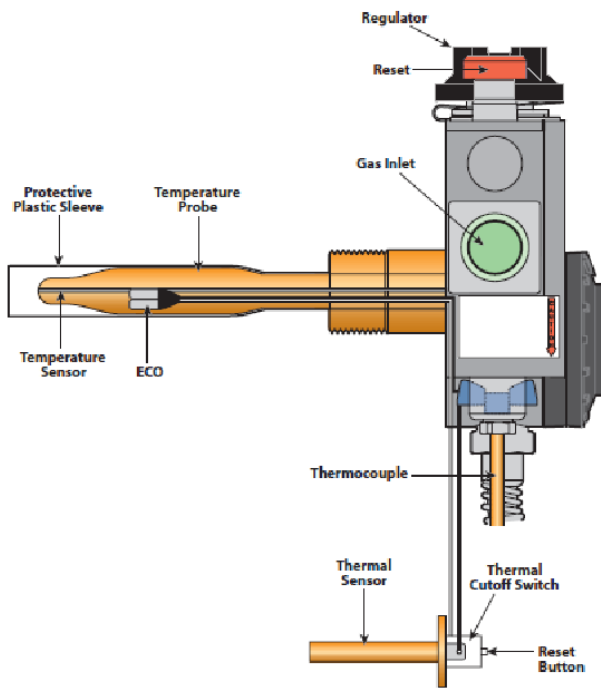

The control circuit for a FVIR water heater is similar to a standard gas water heater. The main difference is the addition of a resettable thermal cutoff switch to the thermocouple circuit.

If flammable vapors are ignited or the flame arrester is blocked, the thermal switch will trip cutting off the gas supply to the pilot and burner

Insufficient combustion air will activate the thermal cutoff switch. When this condition has been corrected, the thermal switch can be reset.





# Gas Water Heater Operation



## Honeywell Equipped FVIR Water Heaters

Spills of gasoline, or the presence of other flammable vapors, near a standard gas water heater can be very dangerous. The American National Standards Institute (ANSI) now requires all residential water heaters to be flammable vapor ignition resistant (FVIR). All Honeywell equipped FVIR **Water Heaters are fully compliant with ANSI FVIR standards.**



Honeywell equipped FVIR water heaters have a sealed combustion chamber. Combustion air and flammable vapors can only enter through a specially designed flame trap. The flame trap is located in the bottom of the combustion chamber under the main burner and pilot flame. If flammable vapors are present, the pilot or main burner can ignite them inside the combustion chamber. The vapors burn on top of the flame trap and have a reduced likelihood from escaping back into the room. When the vapors become too rich or too lean to burn, they snuff themselves out.

A second part of the ANSI Standard concerns resistance to lint, dust, and other debris build-up on the flame trap. If the flame trap were to become clogged, combustion air would be reduced starving the burner of oxygen. This will increase the amount of carbon monoxide and create a health hazard. FVIR water heaters are

designed to reduce lint build-up. The small pressure wave created by lighting the burner during normal operation helps blow accumulated lint off the flame trap. If lint does build up, the thermal cutoff switch will shut down the heater, so the flame trap and the filter may be cleaned.



# Gas Water Heater Operation



In order for a gas water heater water heater to operate, the pilot must be lit. The heat from the pilot flame creates an electrical current in the thermopile. The thermopile generates the power needed to operate the electronic gas control without requiring an external power source.

A temperature limit switch or ECO (Energy Cut Off) sensor located in the gas control valve is used to shut off the water heater if the water temperature gets too hot

The electronic gas control incorporates an LED status indicator with advanced self-diagnostic features. The electronic Gas Valve monitors the operation of the heater and will flash an error code if it identifies an issue.

Insufficient combustion air supply will activate the thermal cutoff switch. When this condition has been corrected, the thermal switch can be reset.



# Gas and Electric Water Heater Parts

## Heat Traps

In some models, a heat trap is installed at the hot water outlet and cold water inlet to reduce standby heat loss. The heat trap saves energy by preventing hot water in the tank from rising into the plumbing lines. Heat traps can be installed internally or externally.

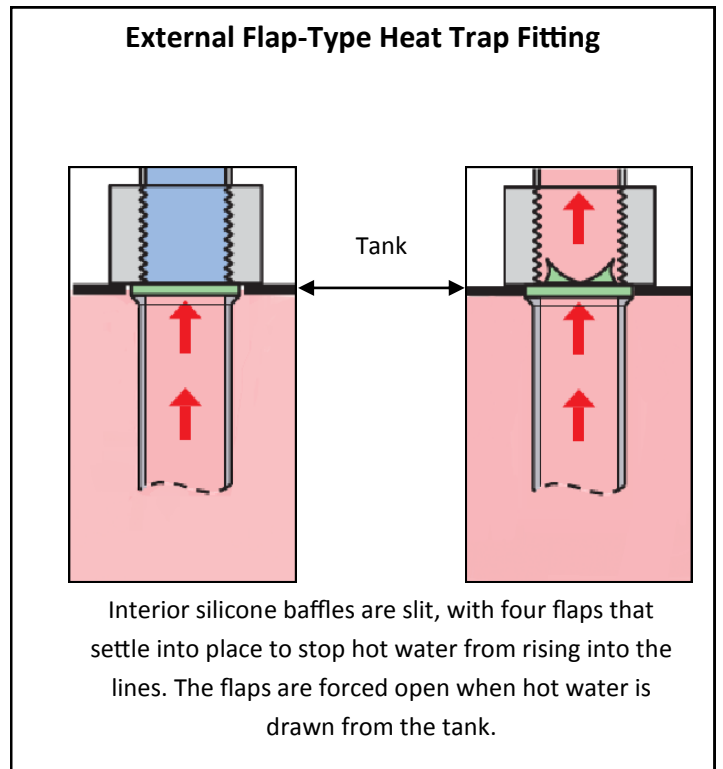
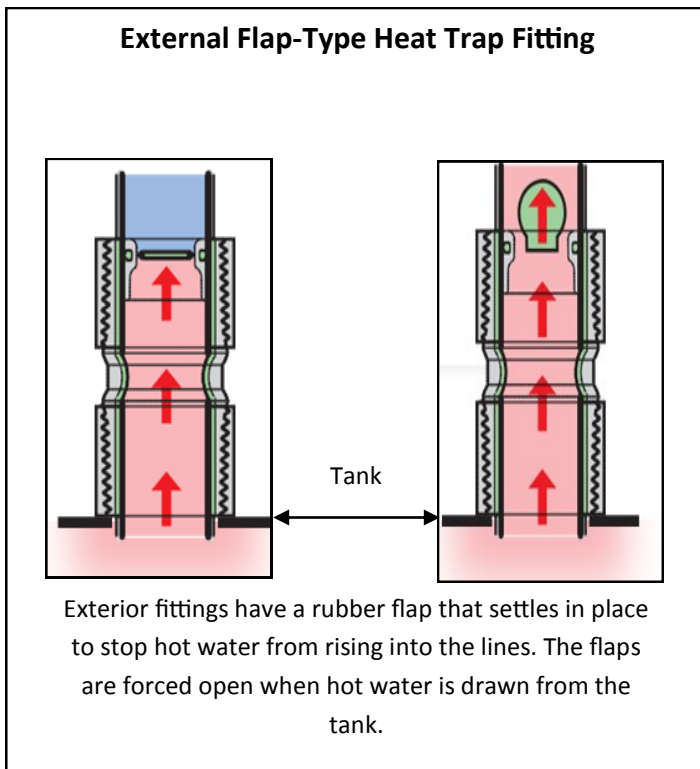
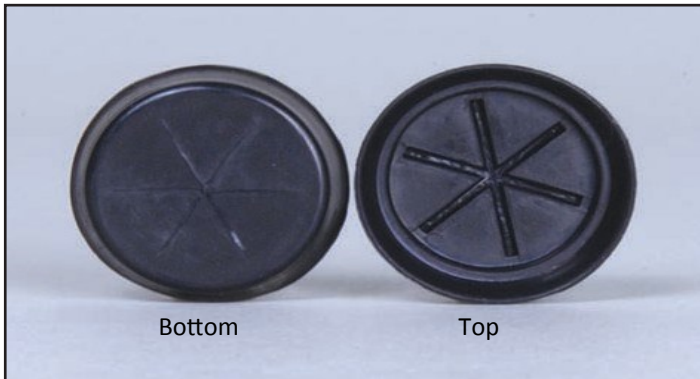

# Gas and Electric Water Heater Parts



**Anode Rod** - The anode rod is a sacrificial part installed to reduce tank corrosion. A tank full of hot water acts very much like a battery with small electrical currents flowing between the different types of metals. The anode rod is made of aluminum, magnesium or an aluminum zinc alloy which is more conductive than the steel of the tank. The electrical currents corrode the anode rod rather than the tank depending on the water.



**T&P Valve** - The T&P, or temperature and pressure relief valve, is a safety device designed to relieve excessive pressure on the tank helping to prevent it from exceeding 150 PSI of pressure.

This valve also activates to cool the tank by discharging water if the temperature inside the tank reaches 210°F. The T&P valve must never be altered, restricted, or blocked as this creates a hazardous situation where the tank could build up pressure and possibly burst.



**Drain Valve** - The child-resistant drain valve is located near the bottom of the water heater and provides a way to drain the water from the heater for maintenance purposes.

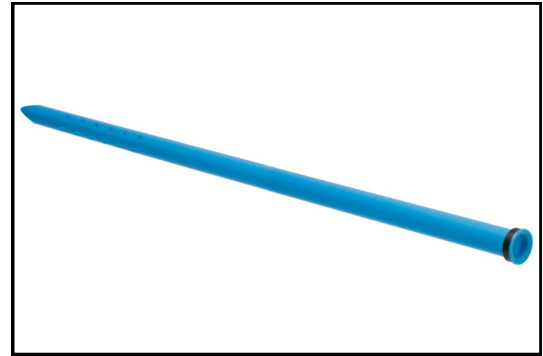

**Dip Tube** - The dip tube moves incoming cold water to the bottom of the tank. This process sometimes causes condensation of flue gasses to occur which can cause a sizzling sound when water droplets fall onto the burner below. This occurrence is not detrimental to the operation of the water heater.



**Combination Dip Tube** - The combination dip tube combines the Dip tube and nipple into one part. The combo dip tube moves incoming cold water to the bottom of the tank. This process sometimes causes condensation of flue gasses to occur which can cause a sizzling sound when water droplets fall onto the burner below. This occurrence is not detrimental to the operation of the water heater.

# Applications

Selecting the right type of water heater depends on the application. The amount of electrical power available, the ability to run vent pipe, as well as the size and shape of the installation area should be considered when selecting a water heater.

## Electric Water Heaters

For an electric water heater it is important to know the voltage available. This is usually 240 Volts. When replacing an existing water heater, replace it with one of the same voltage and wattage.



The diameter and height of the installation area must also be considered. Some models are specifically designed for space constrained areas.



Lowboy models are designed for installation in areas with height restrictions such as under stairs or counter tops or in crawl spaces.



For kitchen installations, a 24" wide Table Top model can be installed as part of a standard 36" high counter top.



## Gas Water Heaters

Failure to properly vent a gas water heater can cause an explosion, fire or carbon monoxide poisoning. All gas water heaters must be vented according to the National Fuel Gas Code. Venting decisions will depend on the location inside the house where the water heater is to be installed. If replacing an existing unit, the vent diameter of the new unit must not exceed the vent diameter of the old unit, or new venting must be installed. Atmospheric venting, direct venting, power venting and power direct venting are all options to be considered.

**Atmospheric venting** is the most common type used. It is terminated into a chimney or through the roof. Double wall pipe is recommended and should be installed in a manner that avoids unnecessary bends which create resistance to the flow of vent gasses.

The buoyancy of hot combustion gas rising through the flue, draft hood and vent pipe allows the water heater to be vented without mechanical assistance.

**Point of use models**, are small capacity models designed for installation under the sink or counter top. They provide small amounts of hot water for hand washing or other small capacity needs. The 2.5 gallon uses a standard 120 Volt line cord which can be plugged into any standard grounded outlet.



## Mobile Homes

Mobile homes require a model that is specifically designed and HUD approved for that type of installation. Some mobile home models have side-located water connections in order to connect to water lines located under the floor.

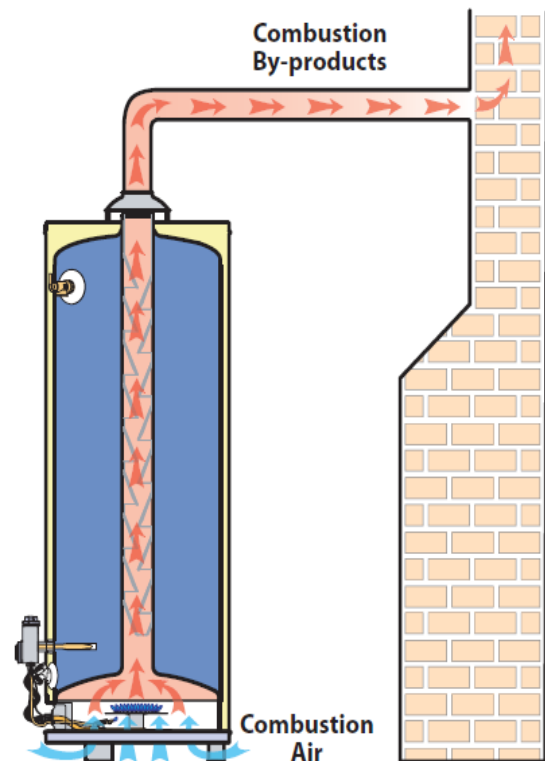



# Applications

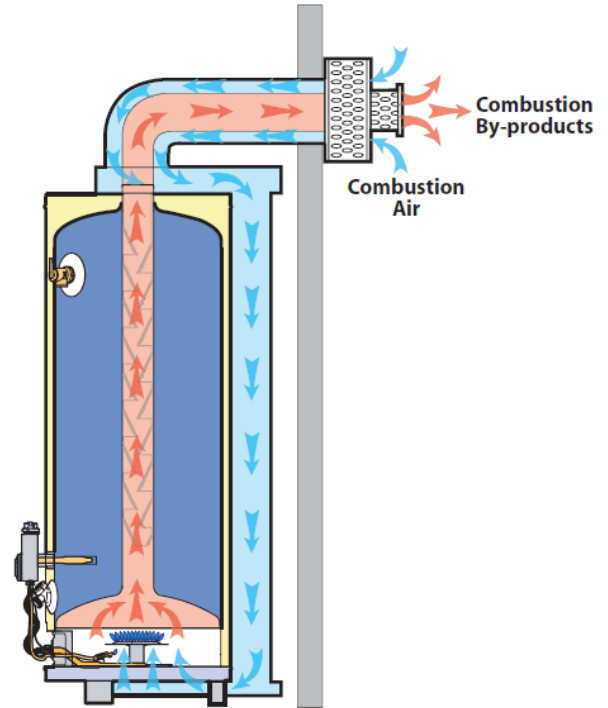

**Direct vent** water heaters also depend on the buoyancy of hot combustion gasses for proper venting but are generally used where vertical venting is not possible or desirable. Because they draw their combustion air from outside the structure, they do not waste conditioned air from inside. The most important consideration with direct venting is that the water heater must be located very close to an exterior wall.

Direct vent water heaters use concentric venting. Combustion air is drawn from outside through a 5" diameter vent pipe. Combustion gasses are vented to outside through a 3" diameter pipe.

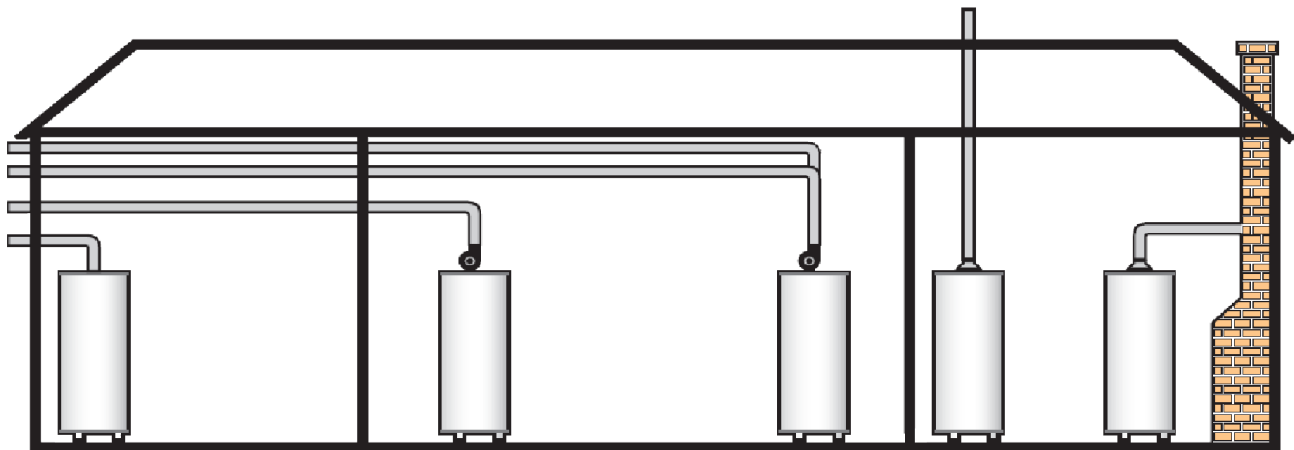

### Direct Vent

All combustion air is drawn from outside the home and exhaust gas is vented to outside using a concentric vent.

### Power Vent

All combustion air is drawn from inside the home and exhaust gas is power vented to the outside using PVC

### Power Direct Vent

All combustion air is drawn from outside the home, and exhaust gas is vented outside, often via PVC pipe. A concentric vent or separate pipes can be used.

### Atmospheric Vent

All combustion air is drawn from inside the home and exhaust gas is vented using metal pipe.



**Power venting** is used when the water heater has to be installed in an interior location of the structure and a long horizontal or vertical vent pipe must be used. Due to lower flue temperatures, they can use PVC, CPVC or ABS pipe depending on the model. The vent pipe can run from 7 feet to as much as 180feet, depending upon the vent pipe diameter, Btu output of the water heater, and the number and type of bends in the vent pipe. Power vent water heaters have a motorized blower located at the top of the flue that forces combustion by-products outside the home. Electricity is required to operate the blower motor.

**Power direct venting** combines the best features of power venting and direct venting. Power direct vented water heaters pull combustion air from outside, but because they use a motorized blower to exhaust combustion by-products using PVC, CPVC or ABS pipe. They can be installed in interior locations using long runs of pipe. They can be concentric vented, or two separate pipes can be used.

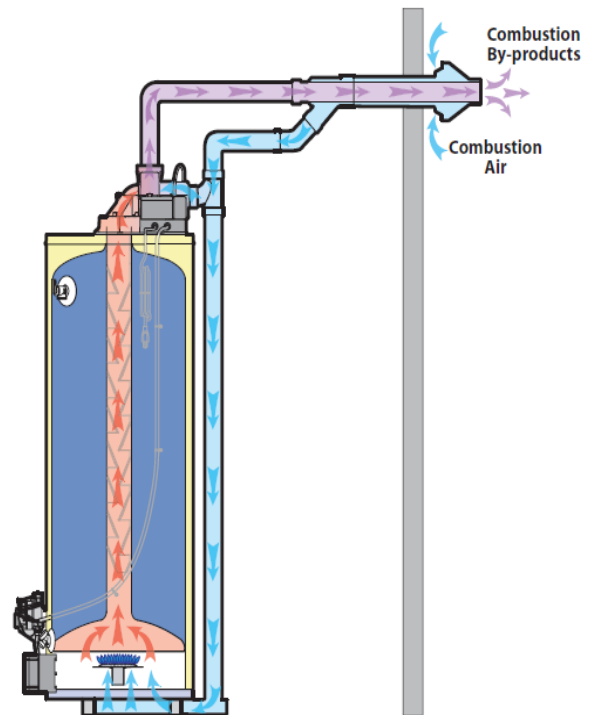
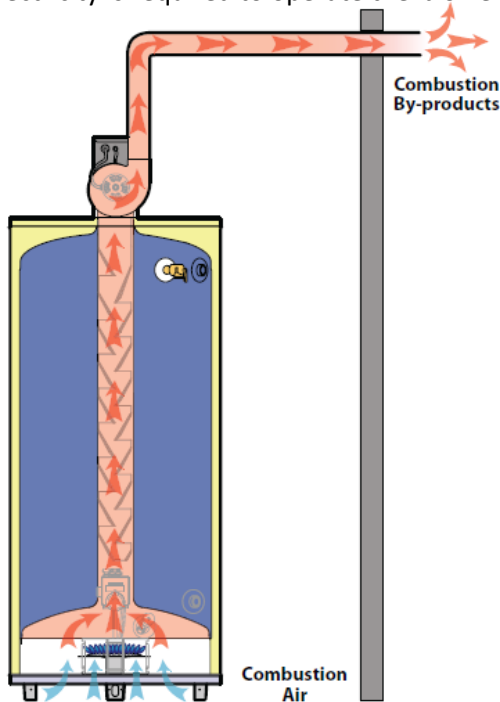

The PV and PDV models may be vented with PVC, ABS, or CPVC pipe.



# Water

The two main sources of water are surface water and ground water. Surface water comes from lakes, streams and reservoirs. Ground water comes from wells. Water sources usually contain some impurities. Most are harmless to people, but some can damage a water heater over time.



## Suspended Solids

Surface water is more likely to contain suspended solids, such as sand, dirt, silt, clay, algae and decaying vegetation. These suspended solids can make water appear murky, or they can be microscopic and not easily visible. Suspended solids will cause staining of sinks, fixtures and clothing. A mechanical filtering system can be installed to remove suspended solids.

## Dissolved Gasses

Ground water is more likely to contain dissolved gasses such as hydrogen sulfide. When water containing hydrogen sulfide is heated, it produces conditions favorable to the growth of sulfate reducing bacteria. This bacteria is harmless but will cause a distinct “rotten egg” smell which is particularly noticeable with the first hot water usage of the day such as a morning shower. This problem can usually be eliminated by installing a continuous chlorination system or increasing the water's temperature to 140 degrees and installing point of use mixing valves set to 120 degrees to reduce the risk of scalding.

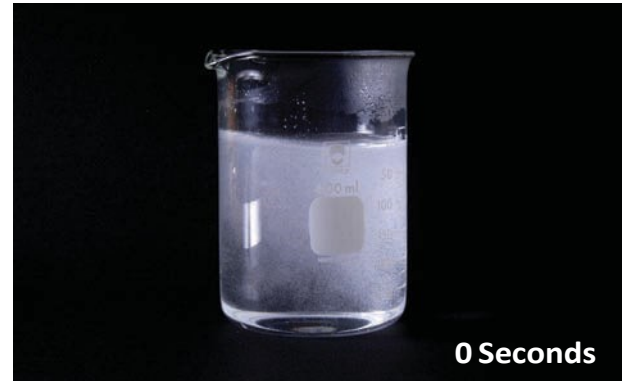

Other dissolved gasses, such as oxygen and chlorine may cause water discoloration. This condition is usually referred to as milky water because the hot water has a whitish color when initially drawn from the tap. When left standing for a few minutes, the water will become clear as the gas bubbles dissipate. This condition is harmless but can be improved by installing aerated faucets.

When the hot water system has not been used for an extended period of time, such as while away on vacation, hydrogen gas may be produced. Hydrogen gas is extremely flammable and will ignite when exposed to a spark or flame. To prevent the possibility of injury, the hot water faucet at the kitchen sink should be opened for several minutes before using any electrical appliance in the immediate vicinity. If hydrogen gas is present, there will be an unusual sound such as air escaping through the faucet as water begins to flow.

## Hard Water

Hard water contains dissolved calcium and magnesium and is harmful to all water heaters. Calcium and

Magnesium combines with other elements in the water and build up as scale. Scale is sometimes referred to as lime deposits. Hard water is most noticeable as a hard-to-remove soap scum on tubs and other bathroom fixtures or as very low sudsing when using detergents. When water is heated, it precipitates this scale into the bottom of the water heater.

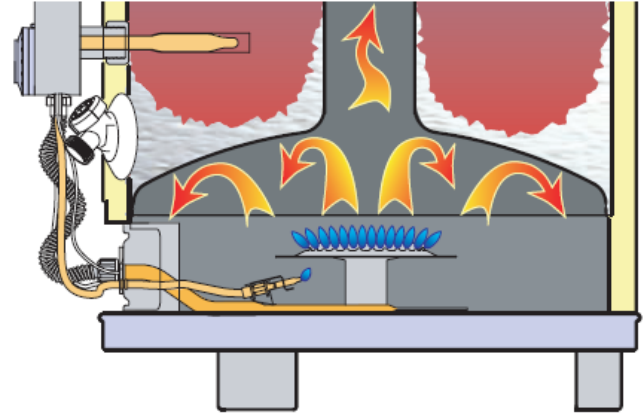
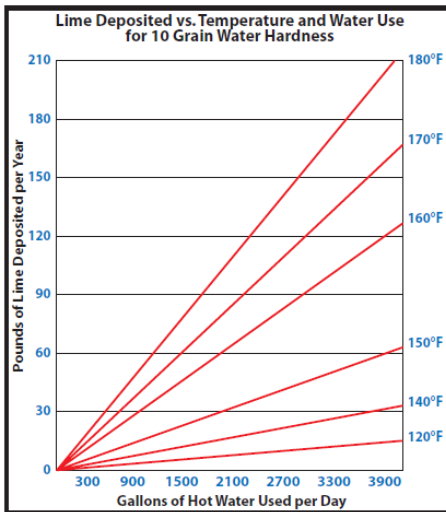

In gas water heaters, scale builds up on the tank bottom head causing small pockets of water and air to be trapped which promotes corrosion. During the heating process, water between the layer of accumulated scale and the bottom head will superheat flashing to steam and causing popping noises. Accumulated scale acts like insulation on the inside of the bottom head resulting in overheating. The stress of being repeatedly overheated will eventually

cause the tank bottom head to leak.

A chemical water softener can be installed to correct hard water problems, but chemical water softeners substitute sodium or potassium ions for calcium and magnesium ions making the water more corrosive. This will also shorten the life of the tank.

## Iron and Manganese

Some water sources may contain iron and manganese. When iron comes in contact with oxygen it turns red or brown. When manganese oxidizes it turns black or brown. Iron and manganese will stain clothing, bathtubs and plumbing fixtures. Both substances can cause water to taste and smell foul. Iron and manganese also combine with bacteria to create a slimy, gelatinous substance that can clog pipes and filter screens. Iron and manganese problems can be improved by installing a mechanical filtering system.



In electric water heaters, scale builds up on the heating elements reducing their ability to transfer heat to the water. This causes the elements to repeatedly overheat stressing the element's outer sheath and causing it to crack or split

# Safety

As water is heated, it becomes more corrosive and expands. These two conditions can create safety issues, but modern water heaters are designed with features to insure safe operation. These concepts and other safety issues will be covered in this section.

## Galvanic Corrosion

A water heater is very much like a large battery. Water is conductive allowing electrical current to pass through it. High concentrations of dissolved minerals and an acidic pH can increase water conductivity.

A water heater tank is made from different types of metal with the tank being mild steel, the elements being copper, and fittings which may be brass, steel, galvanized steel or plastic

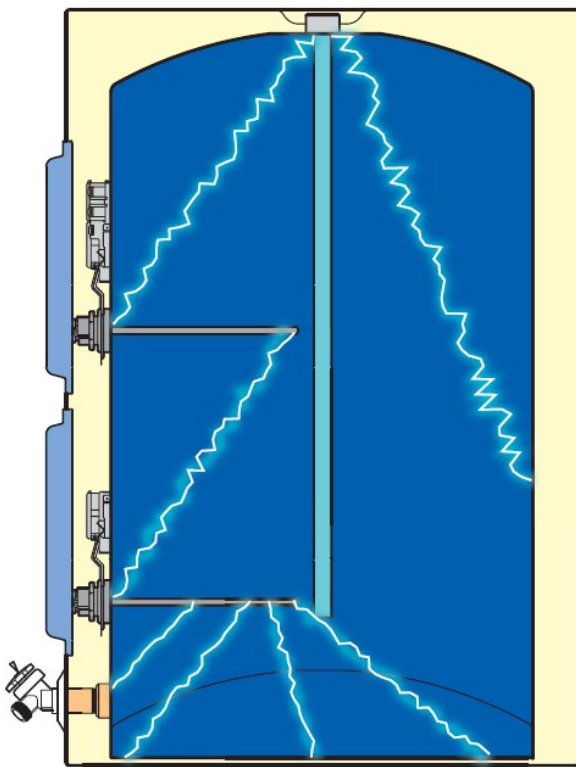

Small electrical currents flow between these different types of materials using the water as a conductor.

The material that the current flows from is called the anode. The material that the current flows to is called the cathode. The anode's surface will corrode. This process is called galvanic corrosion.

The inside of the tank is lined with a glass coating to prevent galvanic corrosion. The coating is sprayed on in a liquid form, dried at about 300°F, then fired at about 1,600°F to fuse the glass to the steel. Although the glass lining provides excellent protection from galvanic corrosion, small unprotected areas may still exist such as the inside of fittings welded to the tank.

To protect any vulnerable areas of the tank, an anode rod is installed. The anode rod is a sacrificial part made of aluminum or magnesium. Electrical current will flow from the anode rod to the tank providing cathodic.



Over time the anode rod will corrode away and will need to be replaced.

Another way to help protect the tank against galvanic corrosion is by installing dielectric water connections. Dielectric connections break the electrical circuit between the tank and the home piping. Dielectric connections provide the most benefit in older homes where galvanized pipes were installed. Newer homes usually have copper or plastic pipes which are less susceptible to galvanic corrosion.

## Thermal Expansion

Water expands as it is heated. For example, 30 gallons of water expands to 30 ½ gallons as it is heated from 40°F to 120°F. Water cannot be compressed, so it will cause pressure to build up in the tank if no expansion area is provided.

In older water systems, expanding water flows from the heater back into the supply line preventing pressure build up. But due to new code restrictions, many areas now require a check valve between the residence and the incoming municipal water supply. The check valve blocks the flow of water back into the supply line causing pressure to build up. This is called a closed water system. A weeping T&P valve or failed toilet valves may indicate a closed water system.

The T&P valve is designed to be an emergency safety valve only and should not be used as an operating pressure relief valve in a closed water system.

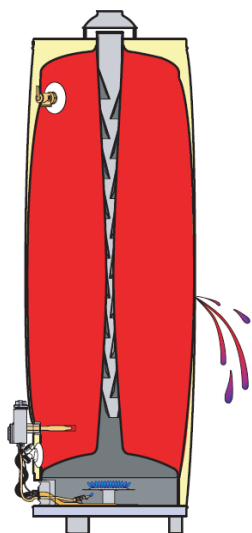

In a gas water heater, excessive pressures can cause the flue to collapse creating a potentially hazardous condition. In both gas and electric models, excessive pressures will eventually cause the tank to fail.

The best solution for closed water systems is the installation of an expansion tank. Expansion tanks are designed to absorb expanding water and relieve pressure on the water heater tank.

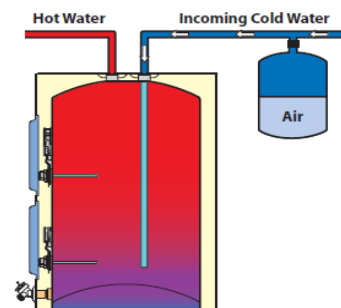

The expansion tank has a rubber bladder with one side of the tank containing air. The air pressure in the tank should be equal to the incoming cold water pressure.

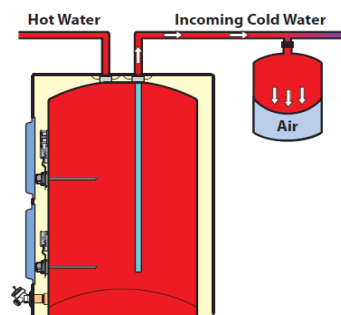

As the water is heated and expands, it is forced back into the expansion tank, compressing the air.

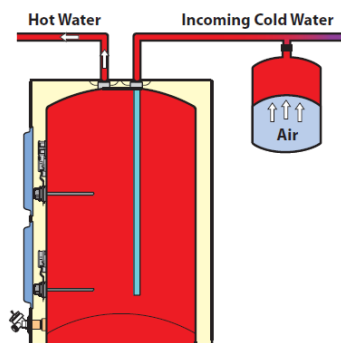

As hot water is used, the compressed air pushes the expanded water out of the tank. This process repeats as water is heated and used.

## Excessive Temperatures

The T&P valve will also activate when the water temperature exceeds 210°F. Activation of the T&P valve for excessive temperatures will result in a large amount of water being discharged and could indicate a problem with the control circuit. This problem should be corrected at once in order to prevent scalding injuries.

Gas water heaters are equipped with an energy cutoff (ECO) switch. It is designed to shut off the gas supply to the unit if the water temperature gets too hot. The ECO is a single use switch and requires complete replacement of the entire thermostat if activated.



Electric water heaters have a high limit control switch, shown above, which will shut off power to the elements if water temperatures exceed about 170°F. This switch can be reset by firmly pushing the red reset button located on the thermostat.

When a series of short draws of hot water are used from the tank, usually 3 gallons or less, it can artificially increase the number and frequency of heating cycles. With each draw, cool water enters the bottom of the tank. The lower thermostat senses a change in temperature activating the lower element or burner. Since a short draw of water does not completely remove all the hot water in the top of the tank, increasing the number of heating cycles adds more temperature to water in the top of the tank. This is called stacking.

Electric water heaters are not as subject to stacking as gas water heaters because, on short draws all the heat produced by the heating element is transferred to the water in the bottom 2/3 of the tank and mixes with the surrounding water.

Gas water heaters can stack up to 30°F. Heat from the burner is transferred through the flue at the top of the water heater as well as through the bottom head. Repeated short draws accompanied by short heating cycles allow the flue to overheat water in the top of the tank without the thermostat sensing it.

Stacking increases the chance of scald injuries. A mixing valve greatly reduces the chance of a scalding injury due to stacking by automatically adjusting the proportion of cold to hot water as water is drawn from the tank. In homes where children, elderly people or the disabled are present, a mixing valve is recommended for general use fixtures.

## Submerged Water Heaters

When a water heater has been submerged in water, such as during a flood, it must be replaced. The operating controls can no longer be considered functionally safe. The insulation surrounding the unit will have become saturated and cannot be fully dried out. This will cause the outer surface of the tank to corrode creating potentially unsafe operating conditions.



## Defining Hot Water

Hot water can be defined in many ways. The most common way to define hot water is by the application. Water temperature that is considered hot for one application may be only warm in a different application and vice versa.

The following chart shows common temperatures used for various applications. Two of the most common temperatures used for residential applications are 105°F for showers and baths and 120-140°F for laundry

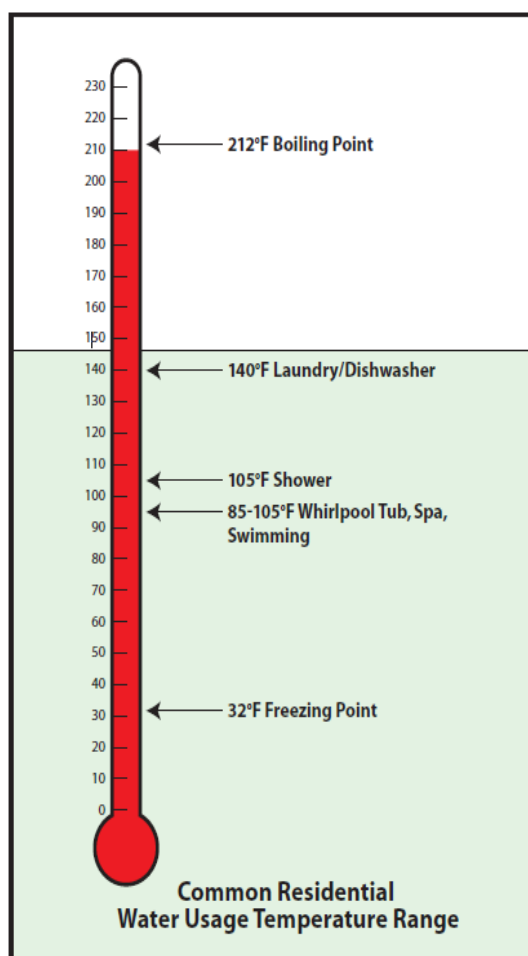

Commercial applications often use much higher temperatures than residential applications. For example, when using hot water for sanitizing dishes, the National Sanitation Foundation (NSF) requires that water be 180°F

Although hot water is defined by its application, it is important to remember that with higher water temperatures comes an increased risk of a scalding injury. Water that is 120°F takes more than 5 minutes to cause a scald injury. Water that is 160°F can scald in less than one second. Small children, elderly people and the disabled are most at risk of scalding injuries. Hot water to general use fixtures, such as lavatories, showers and bathtubs, should be limited to 120°F or less. If water of a higher temperature is required for some applications, a mixing valve should be installed. The mixing valve, or tempering valve, mixes cold water with the hot water supplied to general use fixtures lowering the temperature to within safe limits.

! **WARNING**

**Water temperature over 125°F can cause severe burns instantly or death from scalds.**

**Children, disabled and elderly are at highest risk of being scalded.**

**Feel water before bathing or showering.**

**Tempering valves are recommended.**

Hot water can produce first-degree burns within:

- 120°F (49°C) – more than 5 minutes
- 130°F (54°C) – in 20 seconds
- 140°F (60°C) – in 3 seconds
- 150°F (66°C) – in 1½ seconds
- 160°F (71°C) – in less than 1 second

# Sizing and Performance

Water heaters require routine maintenance to ensure they remain in efficient operating condition. The following components should be periodically checked, and any noted maintenance issues should be immediately addressed.

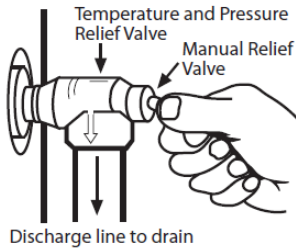

## T&P Valve

The T&P valve should be manually operated at least once a year to insure that it is working properly. Stand clear of the outlet and slowly lift and release the lever handle. Allow the valve to operate freely and return to its closed position. If the valve fails to reset and continues to discharge water, it will need to be replaced.

## Drain and Flush

It is recommended that the tank be drained and flushed periodically to remove sediment which may build up during operation.

## Anode Rod

The anode rod should be visually inspected every year. If it is more than 50% depleted it should be replaced.

## Gas Water Heater Inspection

Gas water heaters should be inspected periodically according to instructions in the installation manual. A visual inspection should be made of the venting system, piping systems, main burner and pilot burner. Look for obstructions, damage or deterioration of the venting system. The pilot and main burner should be free of soot and carbon. Verify that the burner is producing a soft blue flame. The Filter screens should be cleaned every 6 months on FVIR models Also look for leaking or damaged water and gas .

## Lint Buildup - Gas Water Heaters

Lint buildup reduces the amount of combustion air available starving the burner of oxygen. This condition can increase the amount of carbon monoxide released, creating a potential health hazard. It is a good idea to inspect the filter at regular intervals and clean it as necessary to promote good air flow to the unit.



Maintenance videos are located at  
[www.Hotwater101.com](http://www.Hotwater101.com)



# Sizing and Performance

## Determining Efficiency

To determine how much hot water the heater can produce and how fast it can produce it, recovery capacity, recovery efficiency, tank draw efficiency and standby efficiency will have to be considered.

## Recovery Capacity

*Recovery capacity* is the number of gallons of incoming cold water per hour the water heater can heat to a specific temperature. The difference between the incoming cold water temperature and the hot water produced is called the temperature rise.

The following formula is used to calculate the recovery capacity of gas water heaters. Input is measured in BTUs. A *BTU* (British Thermal Unit) is the amount of energy required to heat one pound of water by 1°F.

Input is the rated input of the water heater, as shown on the rating plate. In this example it is 40,000 BTUs. Efficiency is the water heater's recovery efficiency; 75% in this example. The weight of one gallon of water is 8.25 pounds. A 90°F temperature rise is used in this example:

### Calculating Recovery Capacity in Gallons per Hour for Gas Water Heaters

$$\text{Recovery} = \frac{(\text{Input} \times \text{Efficiency})}{(8.25 \times \text{Rise})}$$

Example: A 40,000 BTU gas water heater that has a 75% recovery efficiency with a 90 degree rise.

$$\text{Recovery} = \frac{(40,000 \times .75)}{(8.25 \times 90)} = \frac{30,000}{742.5}$$

**= 40.4 gallons per hour**

The following formula is used to calculate the recovery capacity of electric water heaters. Electric water heaters are considered to be 100% efficient when calculating recovery capacity.

KW represents kilowatts. The number of BTUs in one KW is 3412. The weight of one gallon of water is 8.25 pounds.

### Calculating Recovery Capacity in Gallons per Hour for Electric Water Heaters

$$\text{Recovery} = \frac{(\text{KW} \times 3412)}{(8.25 \times \text{Rise})}$$

Example 1: A 4.5KW electric water heater at 100% efficiency with a 90 degree rise.

$$\text{Recovery} = \frac{(4.5 \times 3412)}{(8.25 \times 90)} = \frac{15,354}{742.5}$$

**= 20.7 gallons per hour**

Example 2: A 5.5KW electric water heater at 100% efficiency with a 90 degree rise.

$$\text{Recovery} = \frac{(5.5 \times 3412)}{(8.25 \times 90)} = \frac{18,766}{742.5}$$

**= 25.3 gallons per hour**

The top example shows that 4.5KW at a 90°F rise will heat 20.7 gallons per hour. The bottom example shows that 5.5KW at a 90°F rise will heat 25.3 gallons of water per hour.

When comparing the results of the previous examples, you might notice that the gas water heater is capable of heating water about twice as fast as the electric model. Gas water heaters have much faster recovery rates due to their higher BTU input. Higher BTU inputs and higher wattages decrease recovery time

# Sizing and Performance

An improperly sized water heater can result in cold bath water, a cold shower or a dishwasher full of dirty dishes. An improperly sized water heater can force users to alter their lifestyles to accommodate it, such as by spacing shower times farther apart. In order to make sure that the water heater selected is the correct one, it is important to know how much hot water will be needed and how fast the water heater can produce it.

## Determining Demand

A simple formula can be used to determine how much hot water the water heater will be required to produce for a specific application. After determining the amount of mixed water required, use the formula to calculate the percentage of hot water that must be provided. Divide the amount of hot water required by the tank draw efficiency. The water heater's storage must be greater than or equal to the final number.

### Percentage of Hot Water Required

$$\text{Hot Water Percentage} = \frac{(M-C)}{(H-C)}$$

M = Mixed Water Temperature

C = Cold Water Temperature

H = Hot Water Temperature

**Example:** A whirlpool tub holds 62 gallons of 105 degree water. If the incoming cold water temperature is 40 degrees and the hot water is store at 140 degrees, what size electric water heater is required?

$$\text{Hot Water Percentage} = \frac{(105-40)}{(140-40)} = \frac{65}{100} = .65$$

$$\text{Hot Water from Storage} = 62 \times .65 = 40 \text{ gallons}$$

$$\text{Water Heater Size} = \frac{40}{.8} = \mathbf{50 \text{ gallons}}$$

A water heater with a 50 gallon capacity would be required in this example.

The number of family members, how many bathrooms, the number of appliances that use hot water and usage patterns will need to be determined in order to select the correct water heater. Appliances such as whirlpool tubs, dishwashers and washing machines need to be considered, as well as how many people will be taking showers and how closely shower times will be spaced. All of this information goes into calculating peak hour demand, the amount of hot water used during the busiest usage time of the day.

### Water Use Per Activity

Activity	Gallons of Hot Water Used
Shower or Bath	20
Shave	2
Wash hands or face	4
Hand wash dishes	4
Automatic Dishwasher	14
Prepare Meal	5
Wash laundry	32

Example: The following activities take place between 7:00 and 8:00 a.m. in order to get a family of four ready for work and school

Mother and father take showers	40
Both children wash face and hands	8
Father shaves	2
Breakfast preparation	5

Peak Hour Demand = 55 gallons

## Recovery Efficiency

*Recovery efficiency*, also called thermal efficiency, is a measure of the total amount of heat produced that gets transferred into the water.

Electric water heaters have a recovery efficiency of about 98%. This is because the heating element is completely submerged inside the tank which means that almost all the heat produced is absorbed by the water. Electric water heaters are not 100% efficient because a very small amount of heat may escape through the head of the element.

Standard gas water heaters usually have a recovery efficiency of 70-83%. Gas water heaters need air for combustion which takes place in the combustion chamber below the bottom head. Only about 70-83% of the heat created by the burner is transferred to the water. The rest is lost as radiant heat loss or escapes up the flue helping the water heater vent combustion by-products.

## Tank Draw Efficiency

*Tank draw efficiency* is a measure of the amount of usable hot water that can be drawn from the tank. As hot water is used, it is replaced at the bottom of the tank by cold water.

The temperature of the hot water stored is reduced as the cold water mixes with it. Water that is 30°F below the thermostat setting is not considered usable because the temperature has dropped too much.

## Standby Efficiency

*Standby efficiency* is a measure of how much heat is lost from the stored water while the water heater is not heating water.

Although water heater tanks are surrounded by a layer of insulation, both electric and gas models will lose a small amount of heat through their outer jacket. Insulation is rated in terms of thermal resistance, called R-value, which indicates the resistance to heat flow. A higher R-value means better insulating effectiveness.

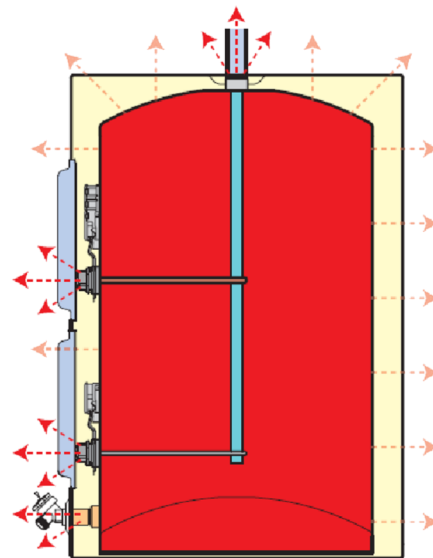

Electric water heaters primarily lose heat through their water connections and piping, around thermostats, heating elements, drain valves, T&P valves and anode rods. Electric water heaters have less than 1% standby heat loss per hour.

Gas water heaters mainly lose heat through their flues as air flows through it picking up heat from the stored water. Heat will also be lost from the combustion chamber which must be open to provide air for the combustion process. Standby heat loss for gas water heaters is typically about 2-4% per hour.

# Testing and Standards

In addition to high internal quality standards, both gas and electric water heater models are subject to safety and efficiency standards set by consumer and government agencies.

## Quality

Quality auditors randomly pull finished water heaters from the assembly line for examination. The auditor has a checklist of possible defects which range from minor to critical. If a critical defect is found, two heaters immediately before and two heaters immediately after the audited unit will be pulled and inspected. If any of these four heaters have defects, four more units will be pulled and inspected. If any of the second group of four show defects, the entire lot will be pulled and inspected.

The Engineering Department also randomly pulls units for testing. These tests are more performance based. They test first hour rating, BTU output, burner reliability and other performance issues.

## Safety

The American National Standards Institute (ANSI) sets safety standards for gas water heaters. The Canadian Standards Association (CSA), formerly known as the Gas Standards Association (GSA), certifies performance of gas water heaters to the ANSI standard.

The Underwriter's Laboratory (UL) sets safety standards for electric water heaters and certifies performance of electric water heaters to the standard.

The government department of Housing and Urban Development (HUD) approves water heaters manufactured for use in mobile homes.

California and Texas have regulations requiring lower nitrogen oxide (NOx) emissions for natural gas water heaters than required by federal standards.

## Efficiency

The National Appliance Energy Conservation Act (NAECA) of 1987 was enacted by congress to set national minimum efficiency standards for gas and electric appliances. Before 1987 some states were setting individual efficiency standards. Now the Department of Energy (DOE) regulates efficiency standards for residential water heaters.

The yellow Energy Guide label is displayed on each model and compares that model's estimated annual operating cost to other similar models. The DOE has a standardized test that measures the overall efficiency of the water heater and translates it into the estimated annual operating cost shown on the yellow label.

The DOE tests combine tank draw efficiency, recovery efficiency and standby efficiency. The result is called an *Energy Factor*. The DOE also measures *First Hour Rating*, which is the amount of usable stored water that is available combined with how much water can be heated in one hour. Both the Energy Factor and the First Hour Rating information is available on the Internet at

<http://www.ahrinet.org/>

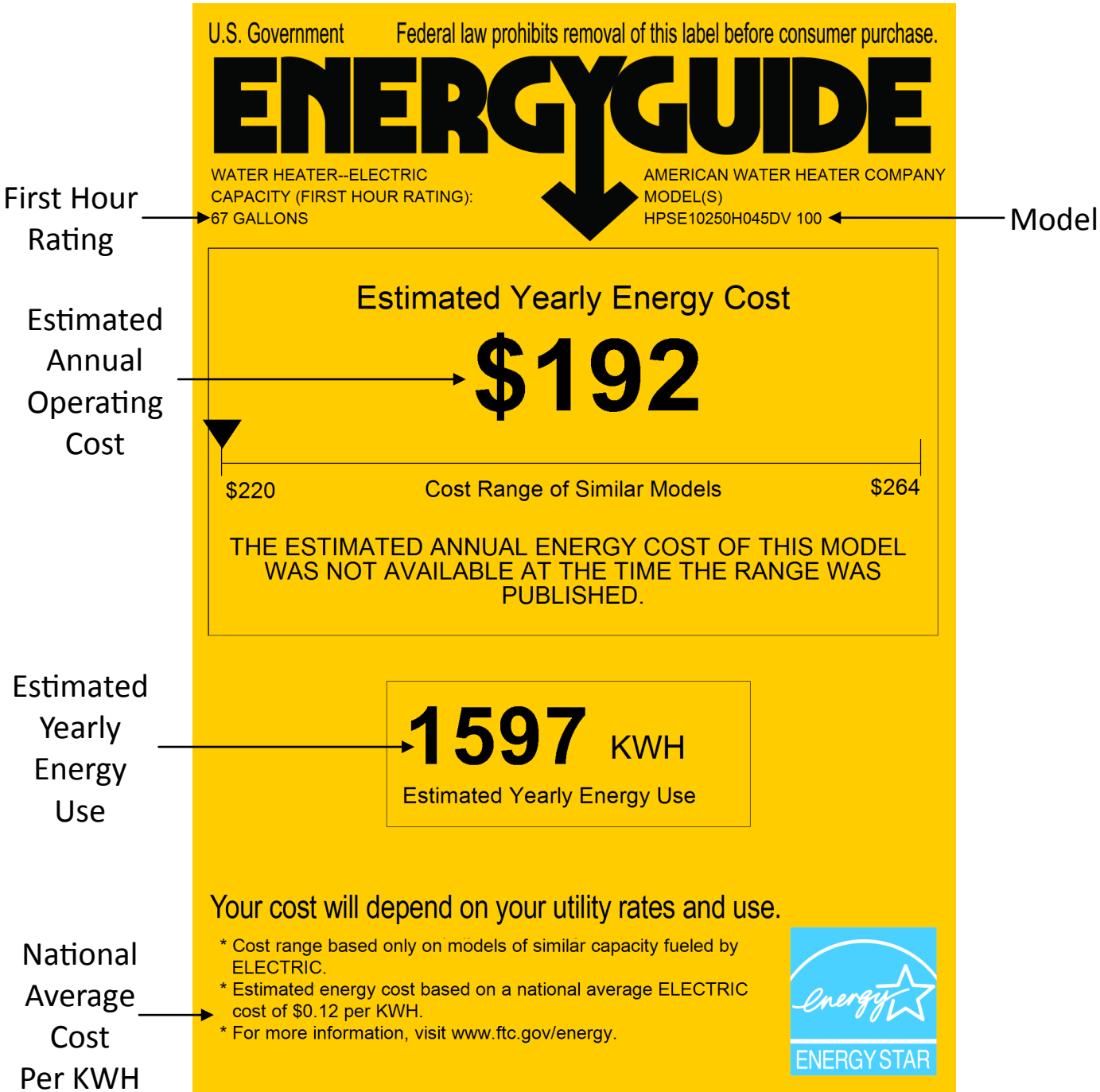

# Definitions

**American National Standards Institute (ANSI)** - Agency that set standards for safety of gas water heaters.

**Anode** - Material that current flows from inside a battery.

**Anode Rod** - Sacrificial part made of aluminum, magnesium or other compounds that is corroded by electrical currents in order to protect the inside of the tank.

**Back Draft** - The back flow of air into the flue. Usually caused by negative air pressure in the home or improper vent termination.

**BTU** - (British Thermal Unit) The amount of energy required to heat one pound of water by 1°F.

**Carbon Monoxide** - Poisonous gas that is a by-product of incomplete combustion. Carbon monoxide is harmful or fatal to breathe and has to be vented to the outdoors. Excessive carbon monoxide is an indication of poor combustion. The cause must be investigated and immediately eliminated.

**Cathode** - Material that current flows to inside a battery.

**Cathodic Protection** - Protection supplied by a sacrificial anode to prevent corrosion of other parts.

**Check Valve** - A one-way valve installed to prevent reverse flow of water in a piping system.

**Closed Water System** - A water system where a check valve prevents the flow of expanding water back into the municipal water supply and includes no provision for thermal expansion.

**Cold Water Inlet Temperature** - The temperature of the water coming from the water supply to the water heater.

**Combustion Chamber** - Part of the gas water heater, located in the jacket base assembly, where the burner is located and combustion takes place.

**Condensation** - Water droplets formed as the temperature drops below the dew point. The amount of condensation is affected by the amount of humidity in the air. A common example is water droplets that form inside the flue and on the bottom tank head when very cold water is introduced into a gas water heater. Condensation may cause a sizzling sound to be heard as the water droplets fall onto the burner below.

**Control Circuit** - Parts that measure tank temperature, direct the unit to begin heating and provide safety controls to prevent overheating or other unsafe operating conditions.

**Dielectric Connections** - Water connectors that stop the flow of electricity from the house piping to the water heater.

**Dip Tube** - Tube that moves incoming cold water to the bottom of the tank to prevent it from mixing with stored hot water at the top of the tank.

**DOE** - (Department of Energy) Government agency that regulates water heater efficiencies.

**Drain Valve** - Child-resistant valve located near the bottom of the water heater to provide a way to drain the water heater for maintenance purposes.

**Dry Firing** - Energizing a heating element before it is completely covered in water. Dry firing will cause the standard heating element to burn out immediately.

**Energy Cutoff Switch** - (ECO) Gas water heater safety device that shuts off gas supply to the unit if water temperature exceeds 180°F. The ECO is a single-use switch and requires complete replacement of the entire thermostat if activated.

**Energy Factor** - Overall efficiency of a water heater calculated by testing tank draw efficiency, recovery efficiency and standby efficiency using the DOE protocol.

**Energy Guide Label** - Yellow label displayed on every water heater that compares that model's energy use to similar models.

**Expansion Tank** - A tank installed on the incoming water line that absorbs expanding water and prevents pressure buildup inside the tank.

**First Hour Rating** - A measure of the amount of usable stored water that is available combined with the quantity of water that can be heated in one hour.

**Flammable Vapors** - Ignitable vapors from liquids such as gasoline, solvents, liquid propane or butane.

**Flue** - The vertical pipe in the center of a gas water heater designed to conduct rising heat into the water and direct combustion by products out the vent.

**Flue Baffle** - A device located in the center of the flue that slows the rising heat and gasses produced by the combustion process, enabling the water to absorb more heat.

**Galvanic Corrosion** - The erosion resulting from electrical current flow from a noble metal (anode) to a less noble metal (cathode).

**Ground Water** - Water that comes from wells.

**Hard Water** - Water that contains dissolved calcium and magnesium. Hardness is measured in grains.

**Heat Trap** - Devices installed on the incoming, and sometimes outgoing, water lines to prevent heat from escaping from the stored hot water.

**Heating Element** - Part of the electric water heater that transfers heat to the water, made up of an inner wire surrounded by filler material enclosed in a copper or stainless steel sheath.

**High Limit Control Switch** - Electric water heater safety device that shuts off power to the elements if water temperature exceeds 170°F. This switch can be reset by firmly pushing on the red reset button.

**Hydrogen Sulfide** - Dissolved gas that is sometimes found in water supplies. When water containing hydrogen sulfide is heated, it promotes the growth of sulfate reducing bacteria that produce a "rotten egg" smell.

**Insulation** - Polyurethane foam, polyester and fiberglass installed between the tank and jacket that prevent standby heat loss.

**Jacket** - Outer covering of the water heater that provides space for insulation and prevents consumers from touching hot tank surfaces.

**Kilowatt** - (KW) Measure of electric power.  
1KW = 1,000 Watts.

**Milky Water** - Water that has small gas bubbles when first drawn from the tap. The bubbles dissipate when the water is left standing for a few minutes.

**Mixing Valve** - (Tempering Valve) Device that mixes cold water with hot water supplied to general use fixtures in order to help prevent scalding injuries.

**National Sanitation Foundation** - (NSF) Organization that sets sanitation standards for the food preparation industry.

**Nipple** - Threaded fittings provided on some models for incoming and outgoing water pipe connections. Most models utilize 3/4" water connections.

**Nitrogen Oxide** - Gas by-product of combustion that is harmful to the earth's atmosphere.

# Definitions

**Pilot Light** - A small flame that stays lit all the time and ignites the burner flame.

**Potable Water** - Water that is suitable for drinking because it contains nothing harmful.

**Radiant Hydronic Heating** - Home heating system that circulates hot water through tubes in the floor or through baseboard heaters.

**Recovery Capacity** - The number of gallons of incoming cold water per hour the water heater can heat to a specific temperature.

**Recovery Efficiency** - (Thermal Efficiency) A measure of the total amount of heat produced by the water heater that is transferred to the water.

**Scale** - Salts formed and deposited inside the water heater or on fixtures. Sometimes referred to as lime deposits.

**Smelly Water** – Usually ground water that contains hydrogen sulfide gas. The smell is caused by sulfate-reducing bacteria that thrive under conditions found inside a water heater.

**Stacking** - Very high temperatures at the top of the tank caused by increased cycling of the burner or heating elements during short draws of water.

**Standby Efficiency** - A measure of how much heat is lost from the stored water while the water heater is not heating water.

**Surface Water** - Water that comes from lakes, streams and reservoirs.

**Suspended Solids** - Small particles of sand, dirt, silt, clay, algae or decaying vegetation that are suspended in water.

**T&P Valve** - (Temperature and Pressure Relief Valve) Safety device that releases hot water when temperatures inside the tank reach 210°F, or when pressure exceeds 150psi.

**Tank** - Part of the water heater that holds the stored hot water. Constructed of welded steel and glass lined to prevent corrosion.

**Tank Draw Efficiency** - A measure of the amount of usable hot water that can be drawn from the tank.

**Temperature Rise** - The difference between the incoming cold water temperature and the hot water produced.

**Thermal Expansion** - Expansion of water as it is heated.

**Thermistor** - Electronic device used in place of a mechanical thermostat that measures water temperature.

**Thermocouple** - Safety device that generates a small electrical current used to energize a safety magnet inside the gas valve.

**Thermostat** - Device that measures water temperature.

**Usable Hot Water** - Water that is less than 20°F below the thermostat setting.

**Watt** - Measure of electric power. 1,000 Watts = 1 Kilowatt

**Working Pressure** - The maximum daily pressure the water heater is rated for, usually 150psi.



American National Standards Institute (ANSI) - 22, 40, 42  
Anode Rod - 4, 7, 12, 13, 14, 25, 30, 32, 36, 39, 40,42  
Atmospheric Venting - 27  
Back Draft - 16, 42  
Burner - 12, 13, 15-16, 18, 20-26, 34, 36, 39, 40, 42  
Calcium - 21, 43  
Canadian Standards Association (CSA) - 40  
Cathode - 32, 42, 43  
Cathodic Protection - 42  
Closed Water System - 33, 42  
Condensation - 25, 42  
Demand - 2, 8, 38  
Department of Energy (DOE) - 40, 42  
Dielectric Water Connections - 32  
Dip Tube - 4, 7, 9, 12-14, 25, 42  
Direct Venting - 16, 27-29  
Dissolved Gasses - 30  
Draft Hood - 12, 13, 16, 27  
Drain Valve - 4, 7, 12, 13, 25, 39, 42  
Element - 4-10, 26, 31, 32, 34, 39, 42-44  
Energy Cutoff (ECO) Switch - 34, 42  
Energy Factor - 40,42  
Excessive Temperatures - 15, 34  
Expansion Tank - 33, 43  
First Hour Rating - 40, 43  
Flame Guard® Water Heaters - 12-16, 20-23  
Flue - 12, 14-16, 19, 29, 33, 34, 39, 42  
Flue Baffle - 12, 43  
Galvanic Corrosion - 32, 43  
Gas Water Heater Inspection - 36  
Ground Water - 30, 43  
Hard Water - 31, 43  
Housing and Urban Development (HUD) - 27, 40  
Hydrogen Gas - 30  
Hydrogen Sulfide - 28, 41  
Insulation - 4, 5, 12, 13, 15, 31, 34, 39, 43  
Iron - 31  
Lime Deposits - 31  
Lint - 20, 22, 36  
Lowboy Water Heaters - 26  
Magnesium - 25, 31, 32, 42, 43  
Manganese - 31  
Manual Reset High Limit Switch - 9, 10  
Milky Water - 30, 41, 43  
Mixing Valve - 34, 35, 43  
National Sanitation Foundation (NSF) - 35, 43  
Nitrogen Oxide (NOx) - 16, 40, 43  
Peak Hour Demand - 38  
Percentage of Hot Water Required - 38  
Pilot - 12, 13 16, 18, 20, 21-23, 36,44  
Power Venting - 27, 29  
Recovery Capacity - 37, 44  
Recovery Efficiency - 35, 39, 40, 44  
R-Value - 39  
Scalding - 34, 35, 43  
Scale - 31, 44  
Single Element Water Heaters - 6, 10  
Stacking - 34, 44  
Standby Efficiency - 37, 39, 40, 42, 44  
Submerged Water Heater - 34  
Sulfate Reducing Bacteria - 30, 43, 44  
Surface Water - 30, 44  
Suspended Solids - 30, 44  
T&P Valve - 4, 7, 12-14, 25, 33, 34, 36, 39, 44  
T&P Valve Inspection - 36  
Table Top Water Heaters - 26  
Tank Draw Efficiency - 37-40, 42, 44  
Temperature Rise - 37, 44  
Thermal Cutoff Switch - 20-23  
Thermal Expansion - 33, 42, 44  
Thermistor - 7, 44  
Thermocouple - 12, 13, 18, 21, 44  
Tiny Titan® - 27  
Underwriter's Laboratory (UL) - 40  
Venting - 16, 27, 28, 29, 30, 36  
Voltage - 26  
Water Use Per Activity - 38





